

# FabHouse

## Assembly Manual

Version 1.0

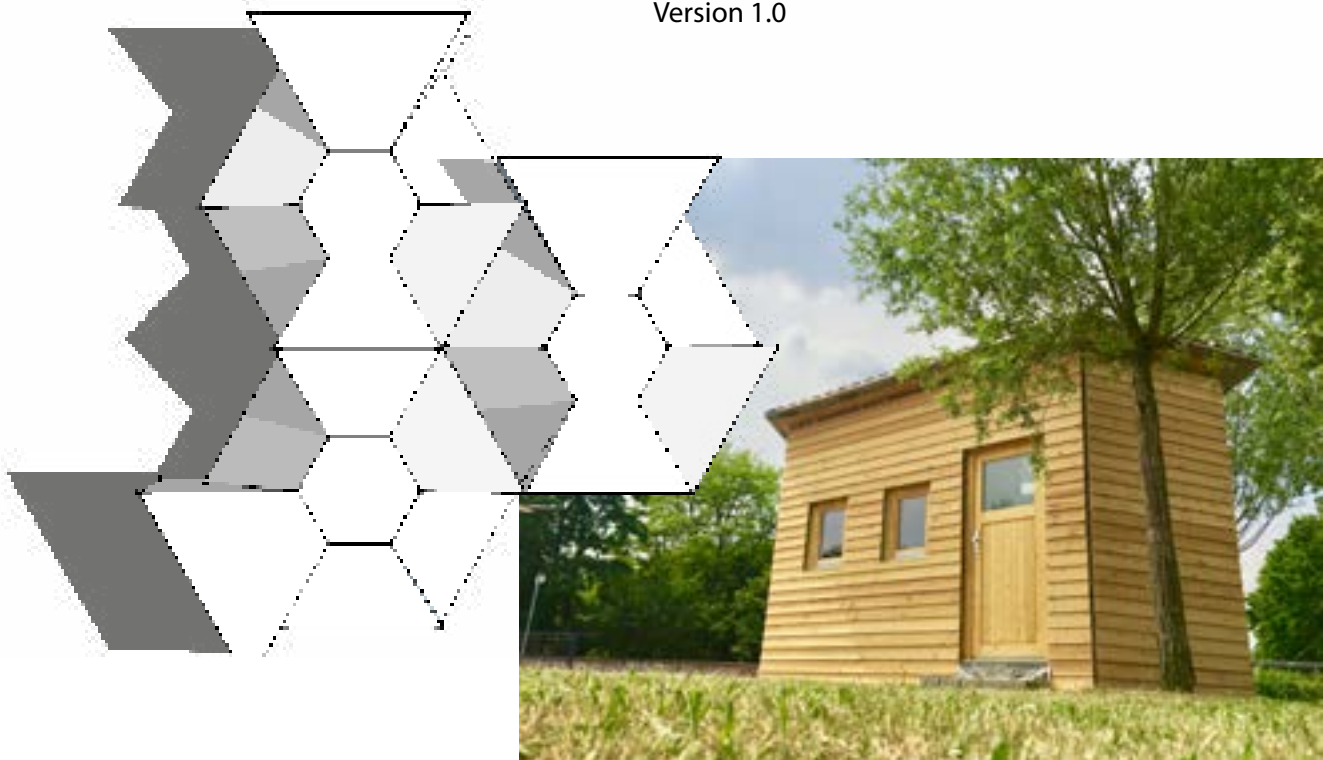

FabHouse was made in a interdisciplinary course at Rhine-Waal University of Applied Sciences in winter term 2017-2018. The Fab House, is generally inspired by the tiny house movement and in particular by the [Wikihouse](#) and the Earthships, which favors not only environmentally friendly and affordable living but also a natural life and democratic house building.

Details about the project can be found at <http://fablab.hochschule-rhein-waal.de/fabhouse/>



This work is licensed under a Creative Commons  
Attribution-NonCommercial-ShareAlike 4.0 International License.

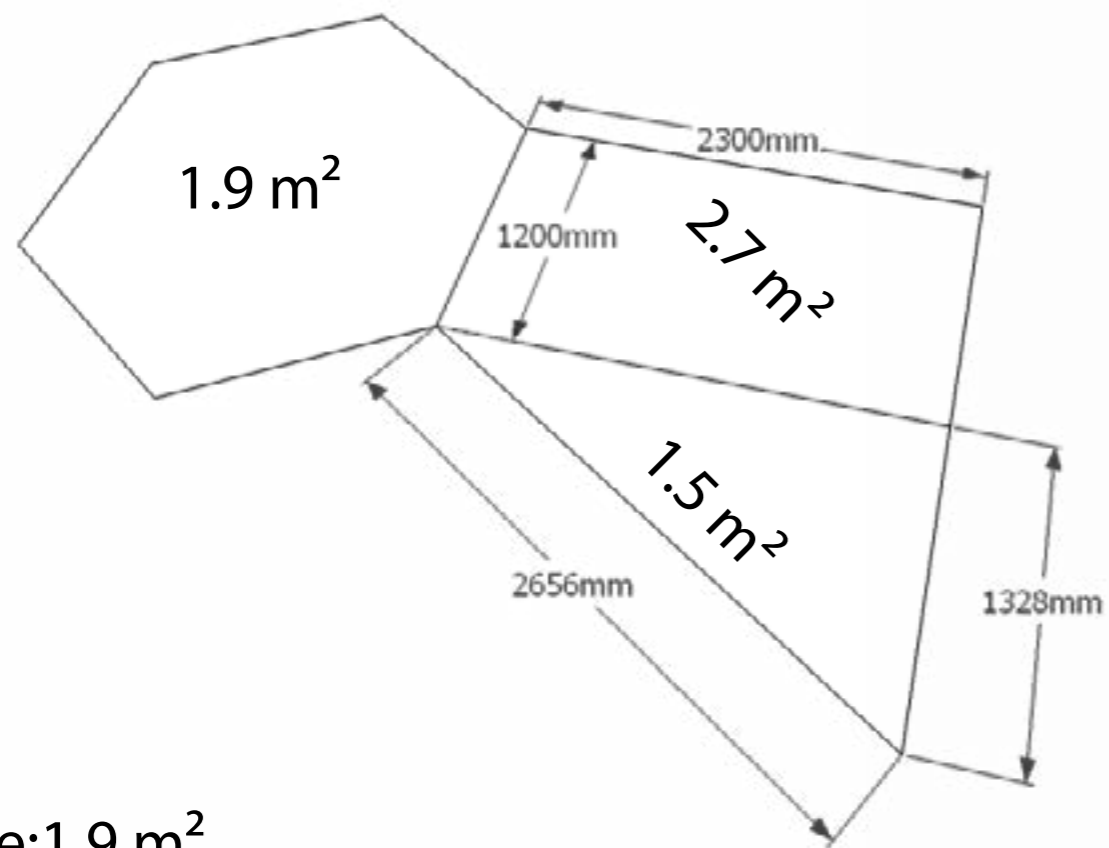

Core: 1.9 m<sup>2</sup>  
 Middle: 2.7 m<sup>2</sup>  
 Corner: 1.5 m<sup>2</sup>

The FabHouse is growing from the center of the core with three modules attached.

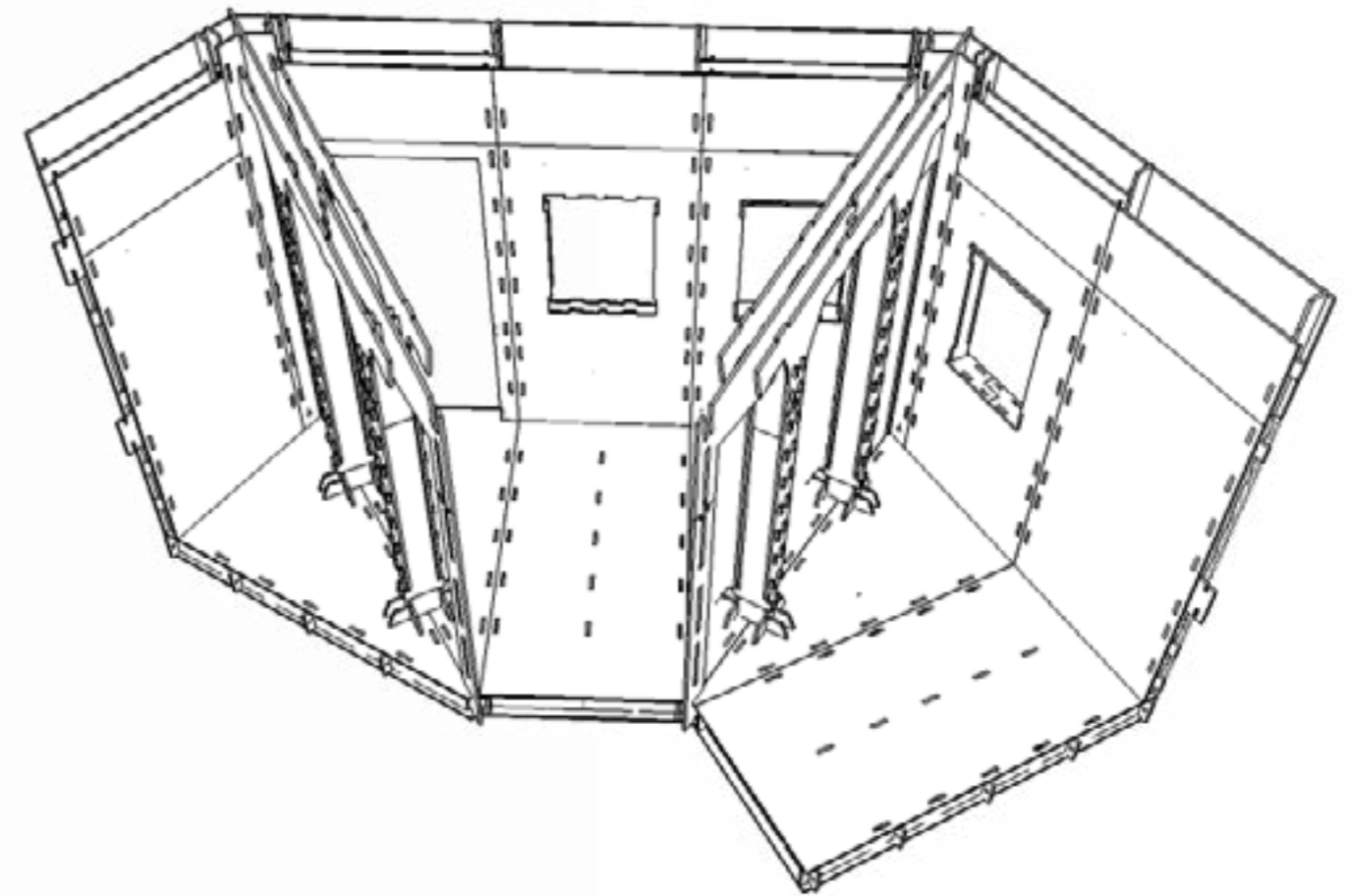

FabHouse  
 12m<sup>2</sup>  
 30m<sup>3</sup>

The FabHouse, that was built at the Fab-Lab Kamp-Lintfort has 2 middle, 2 key and 4 corner parts.

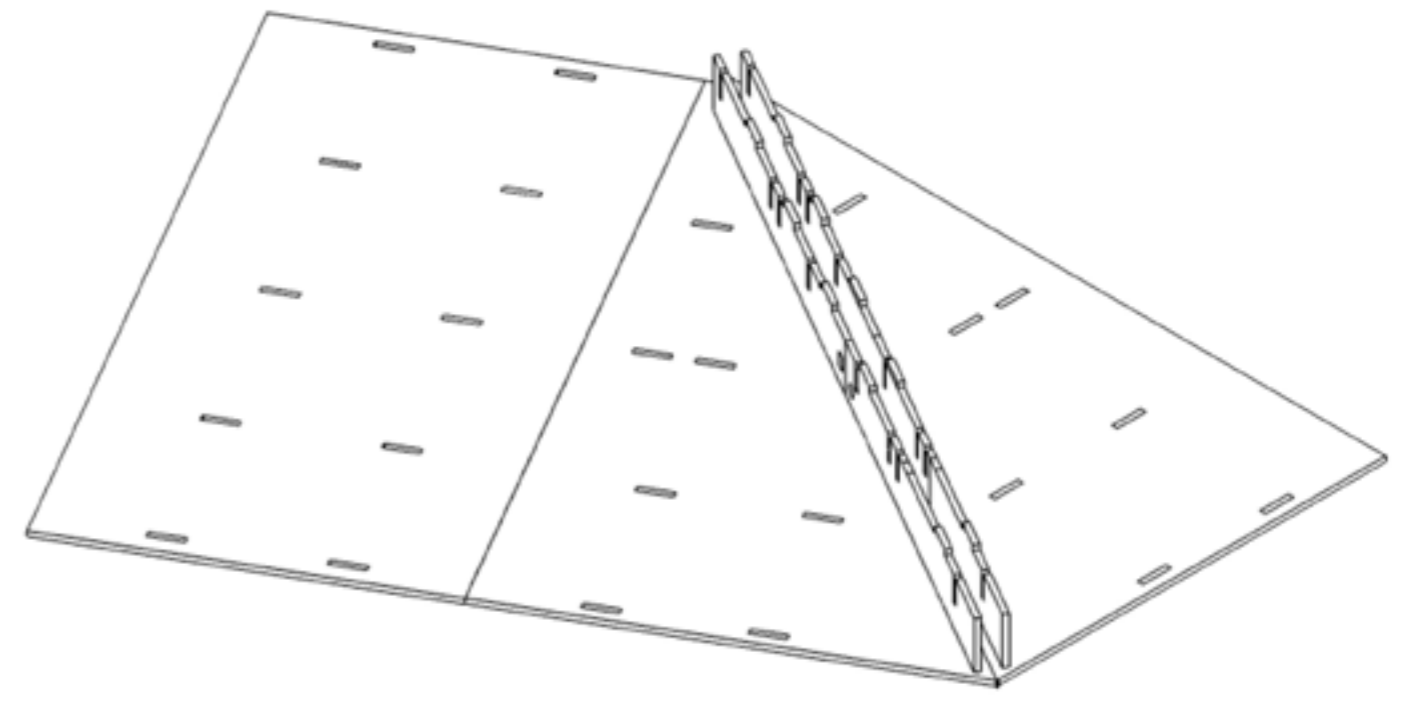
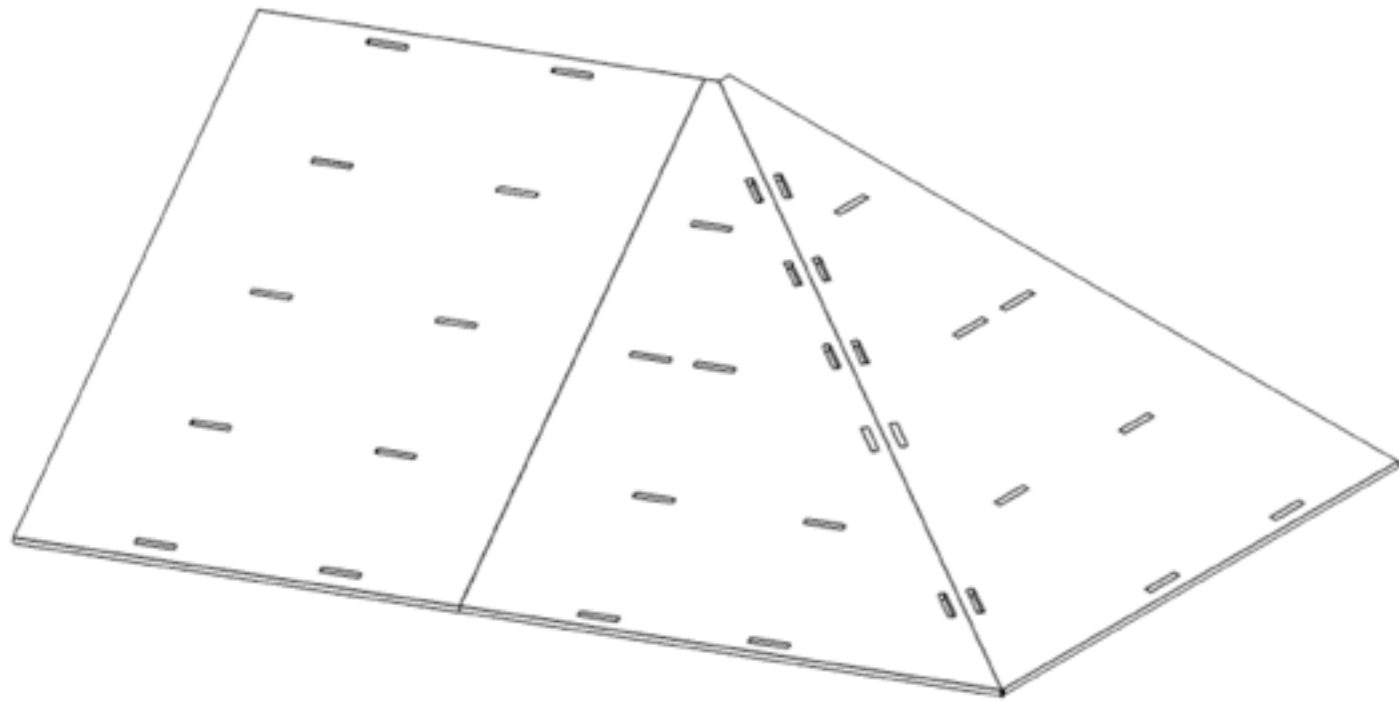
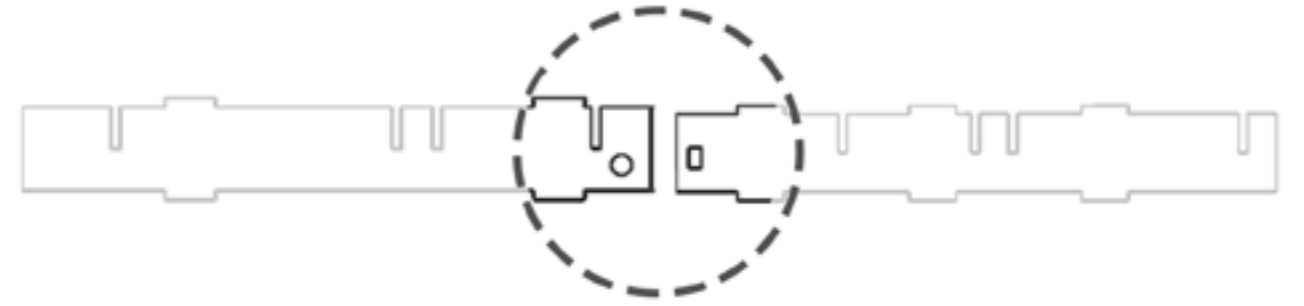
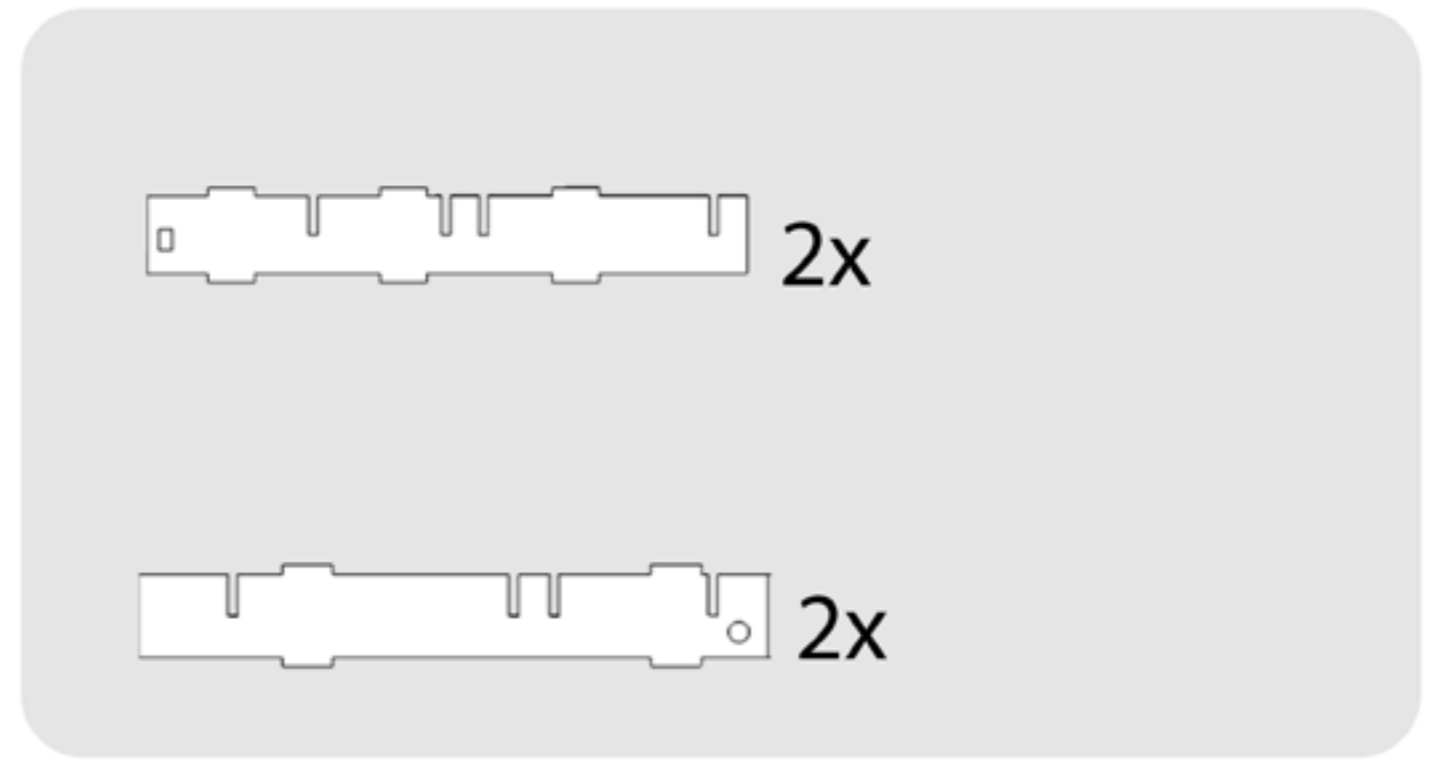
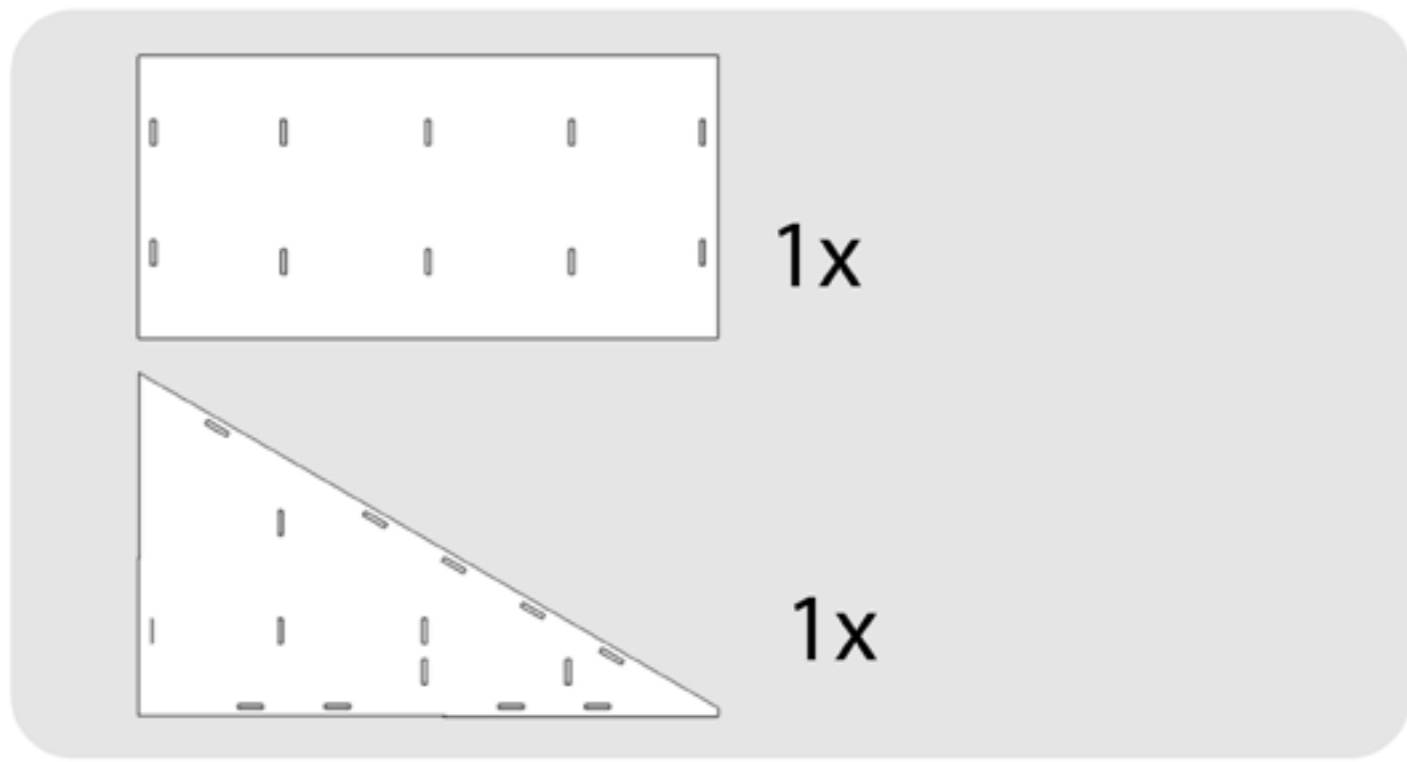

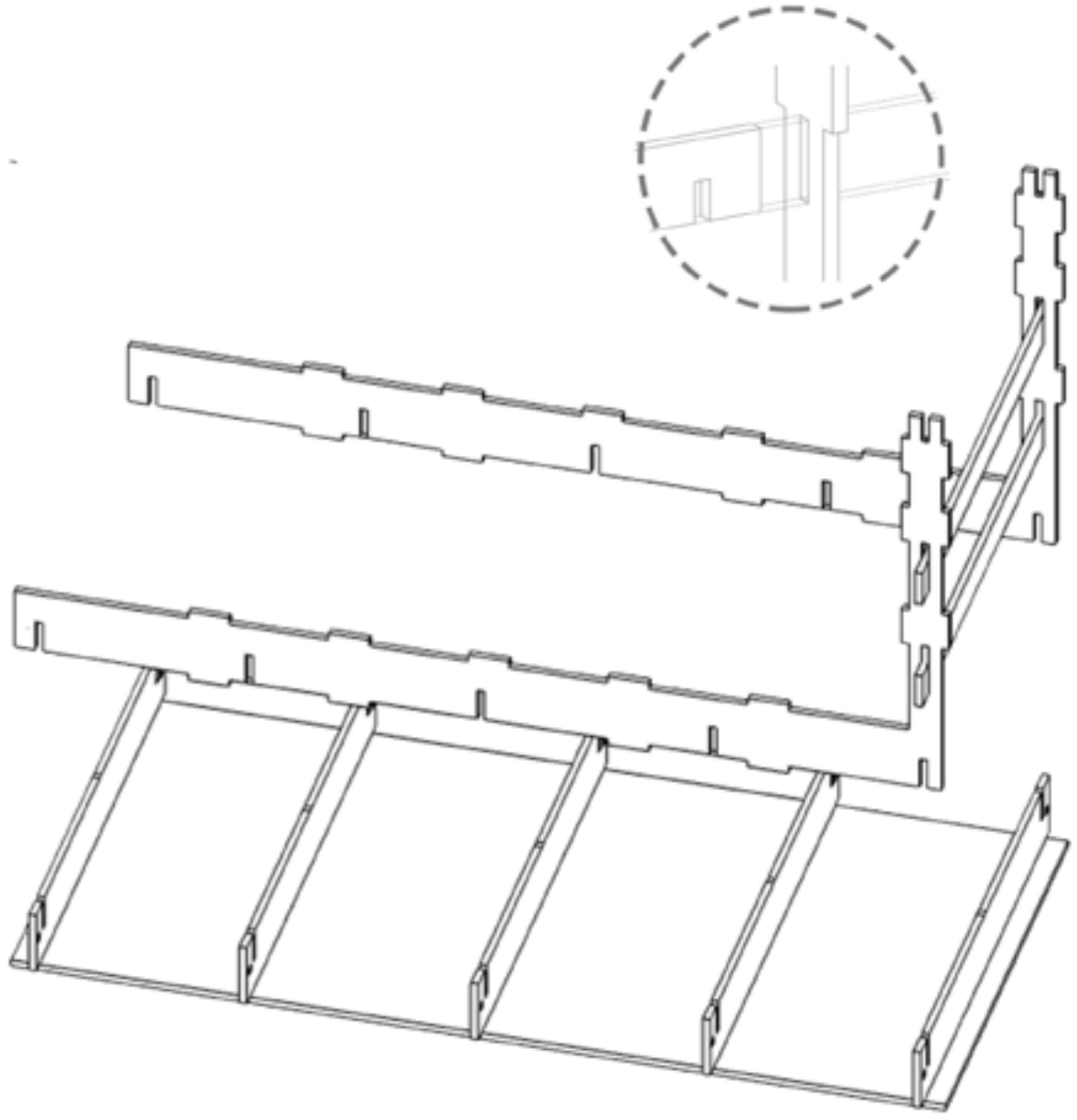
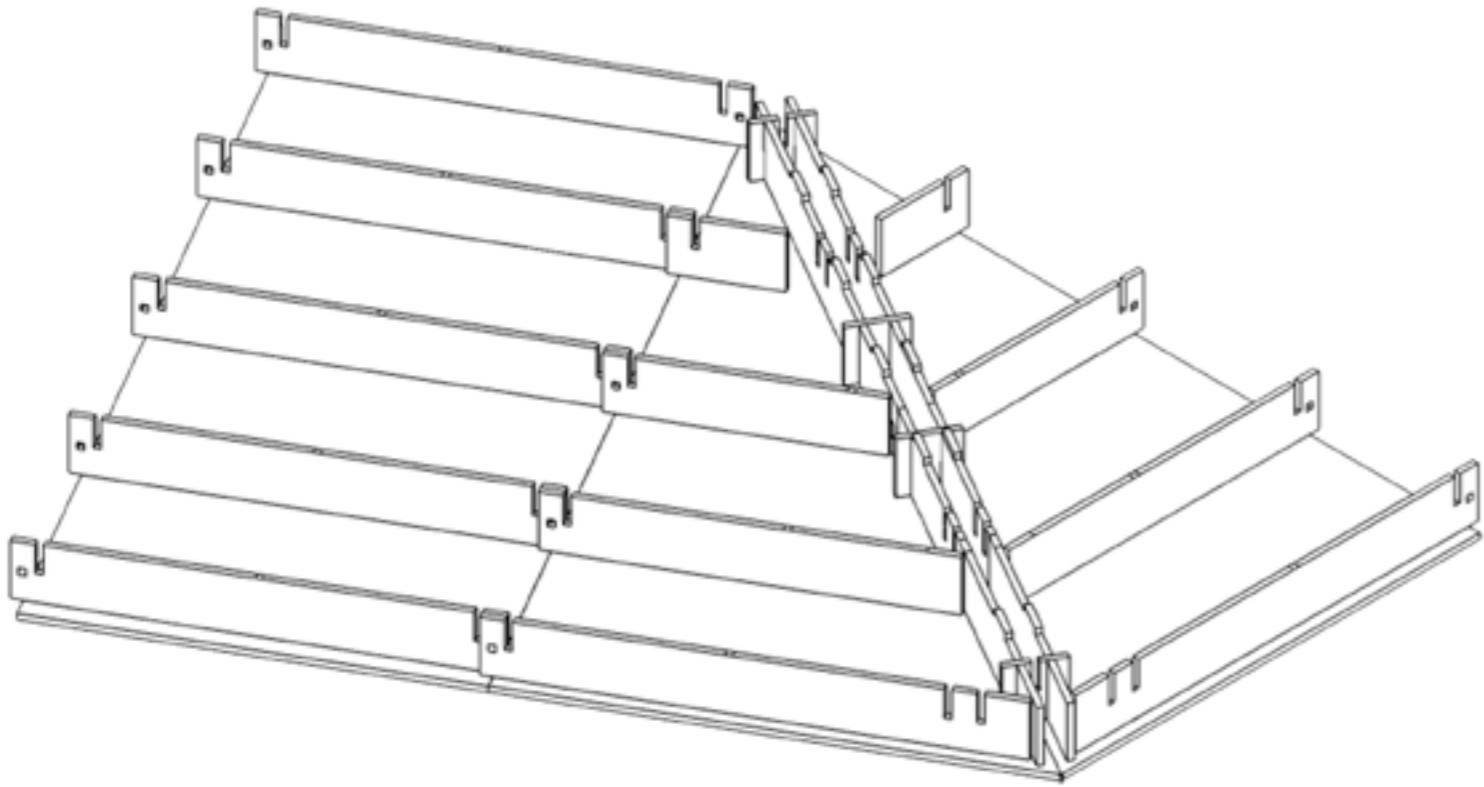
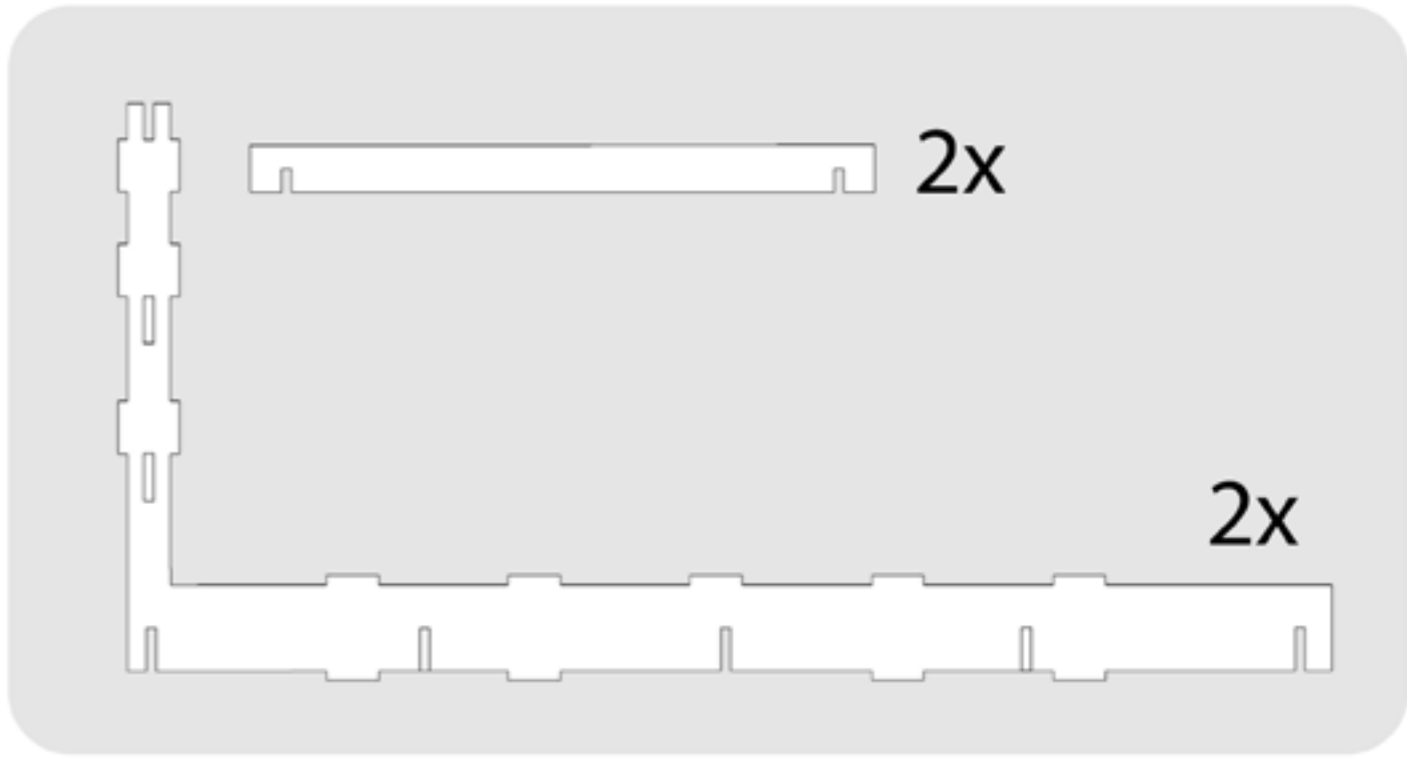
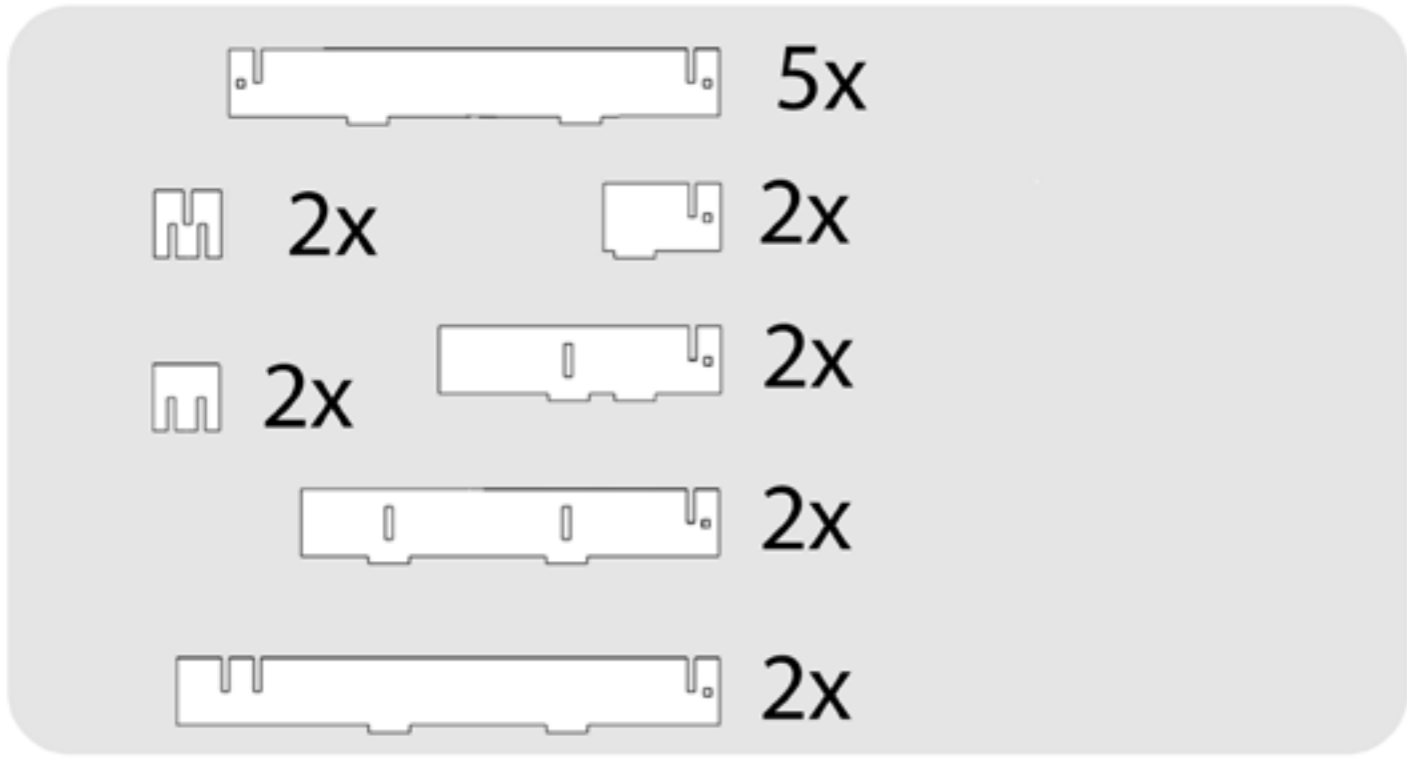

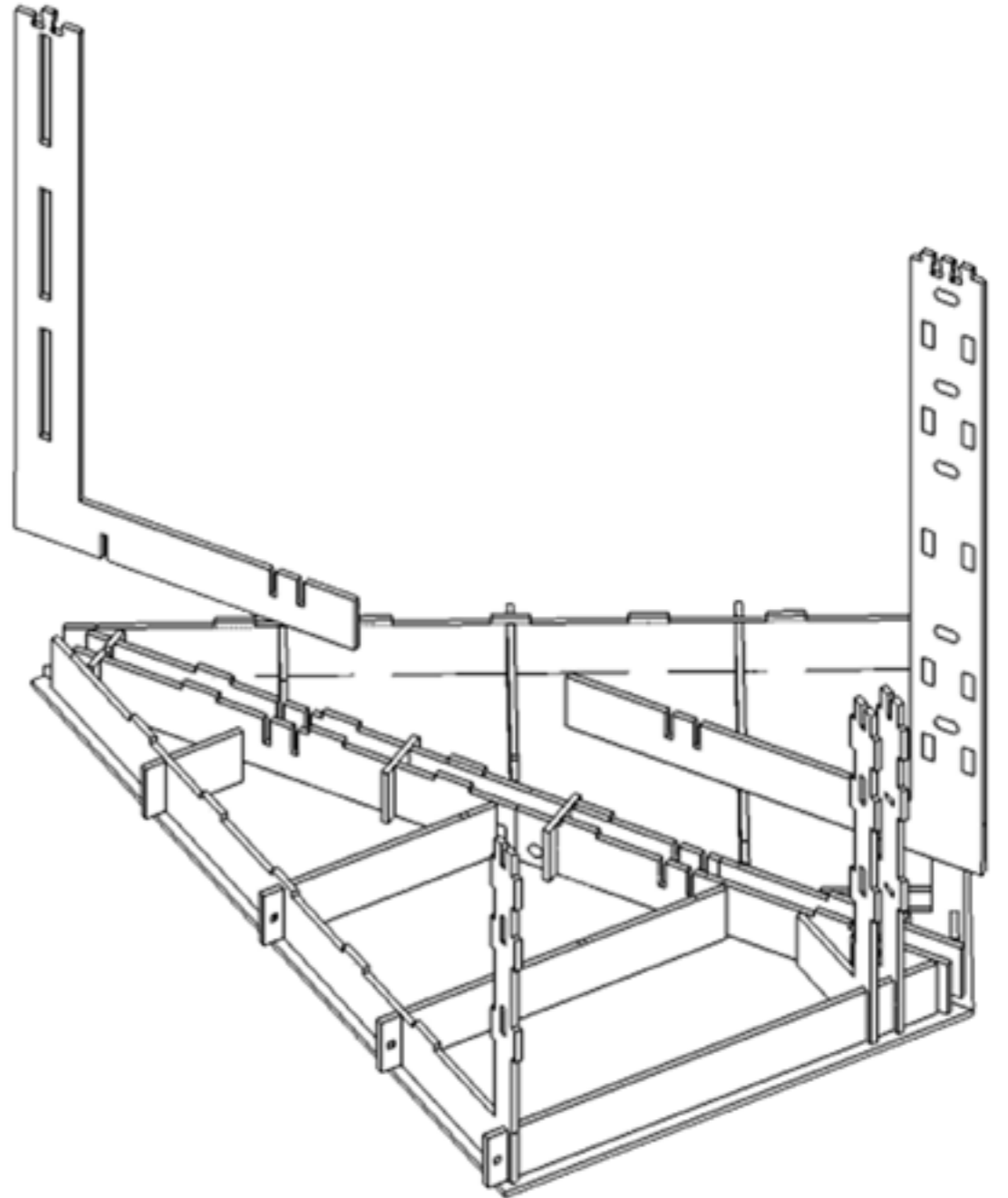
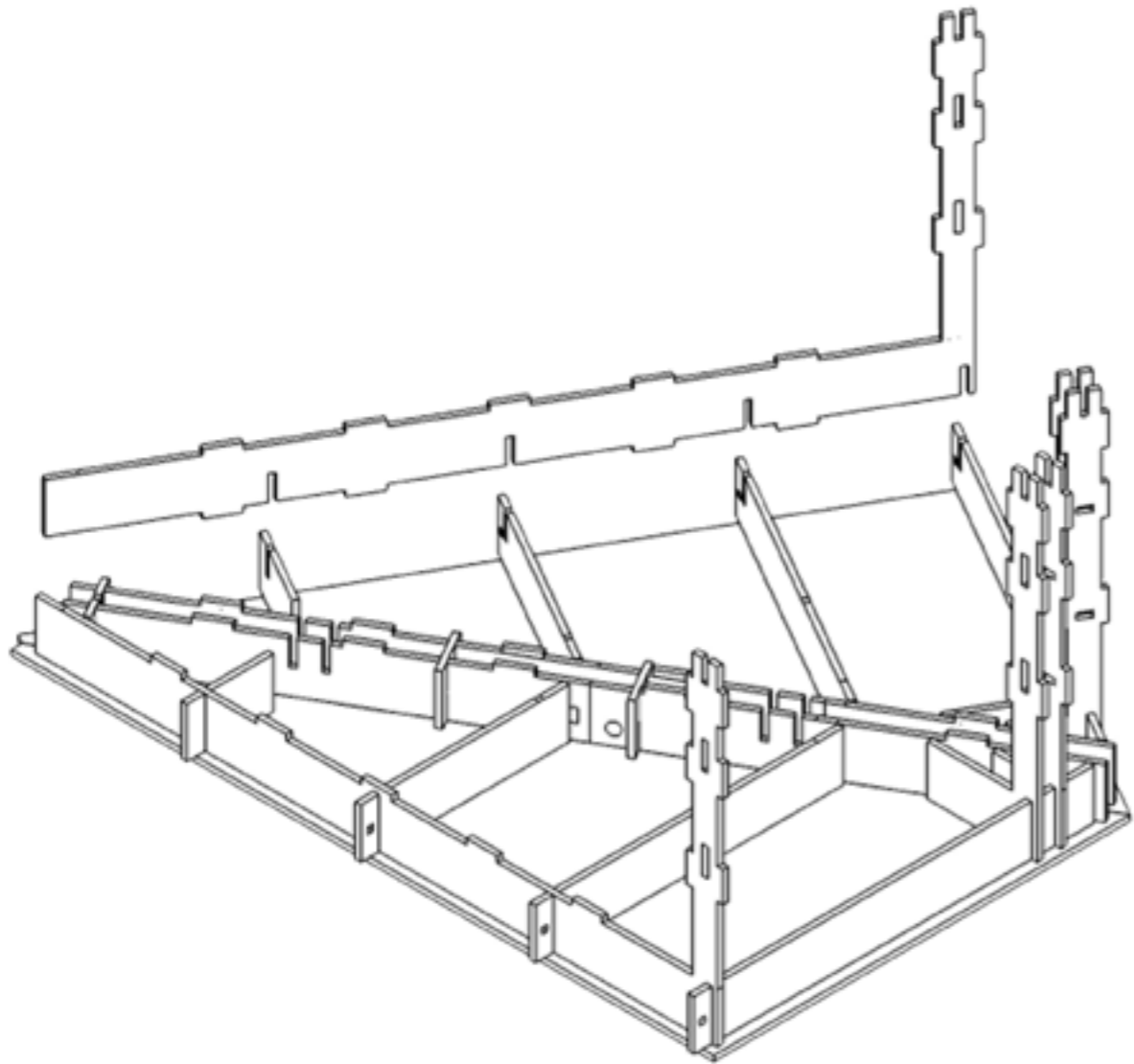
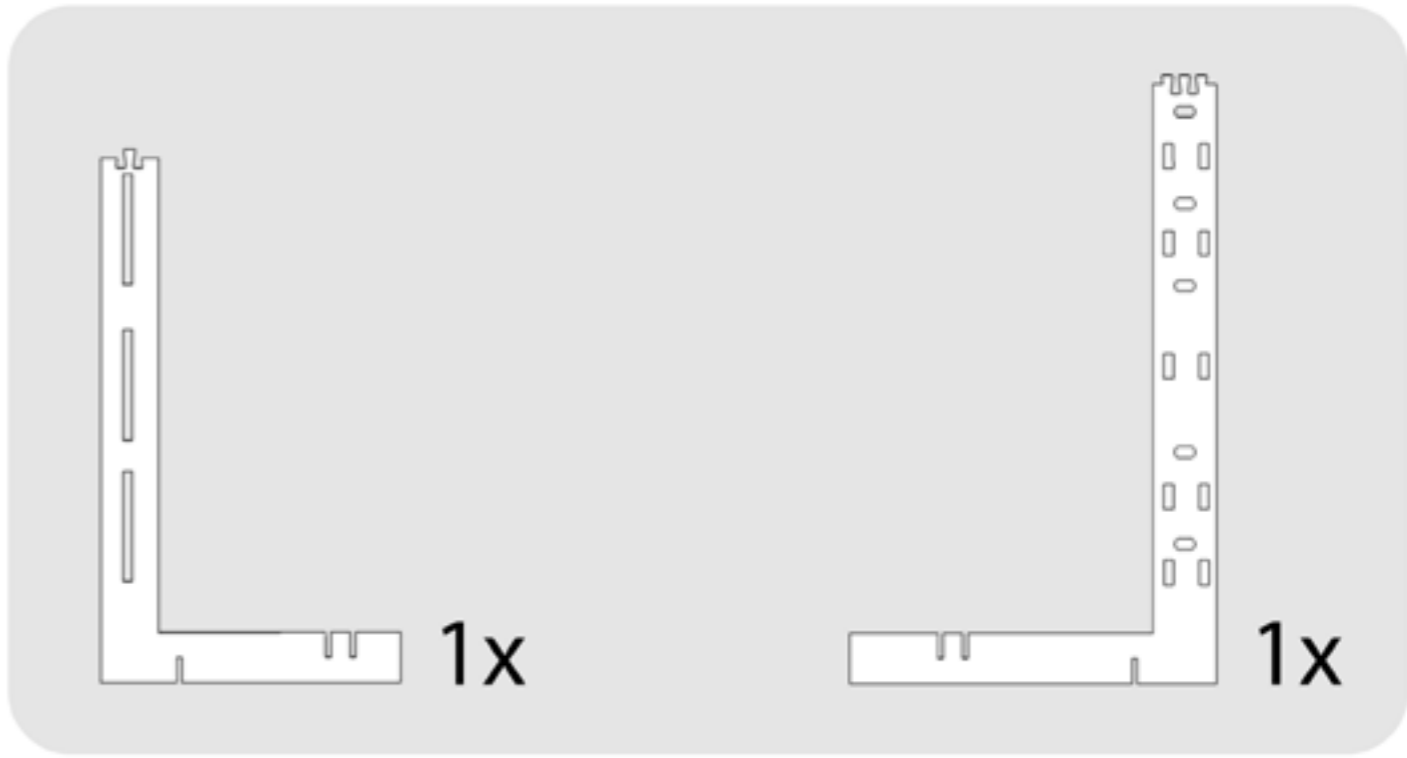
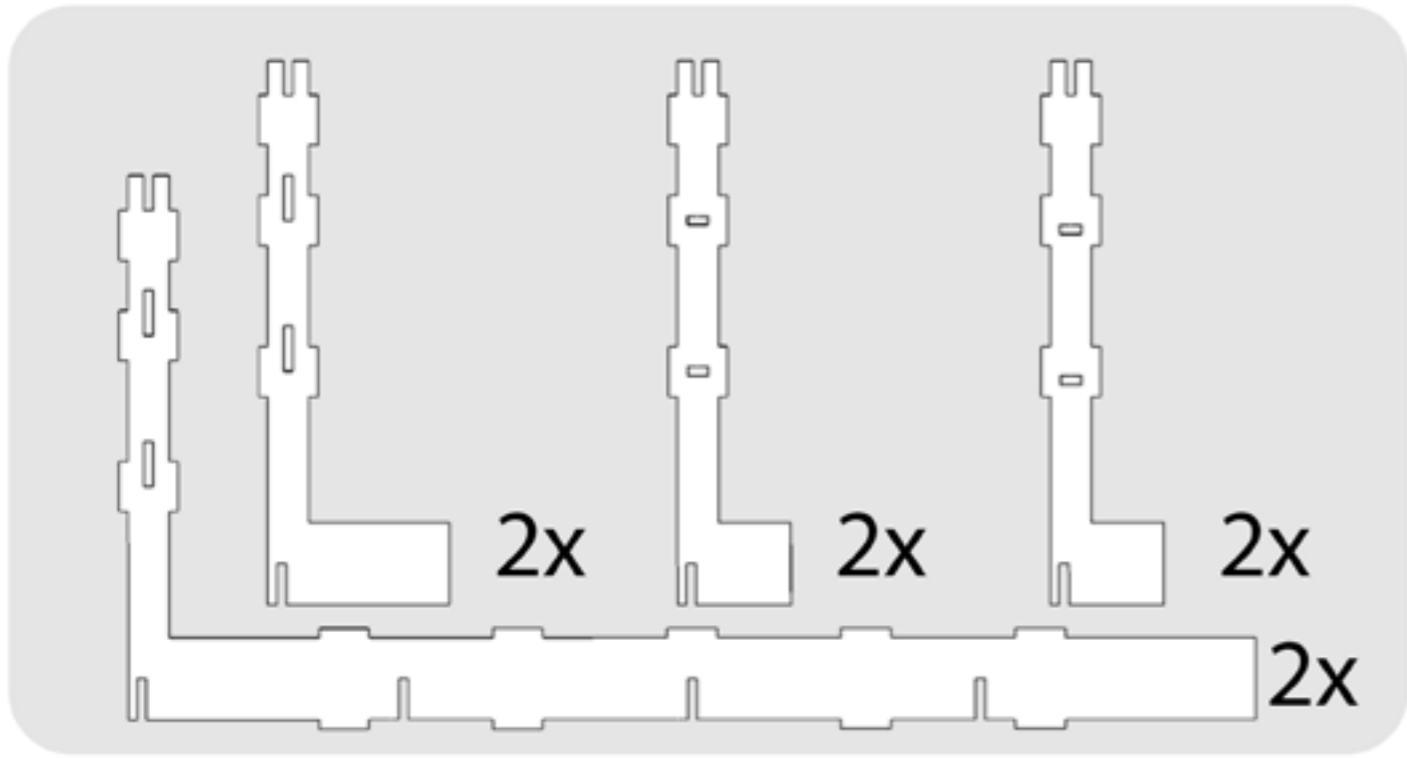

# Insulation

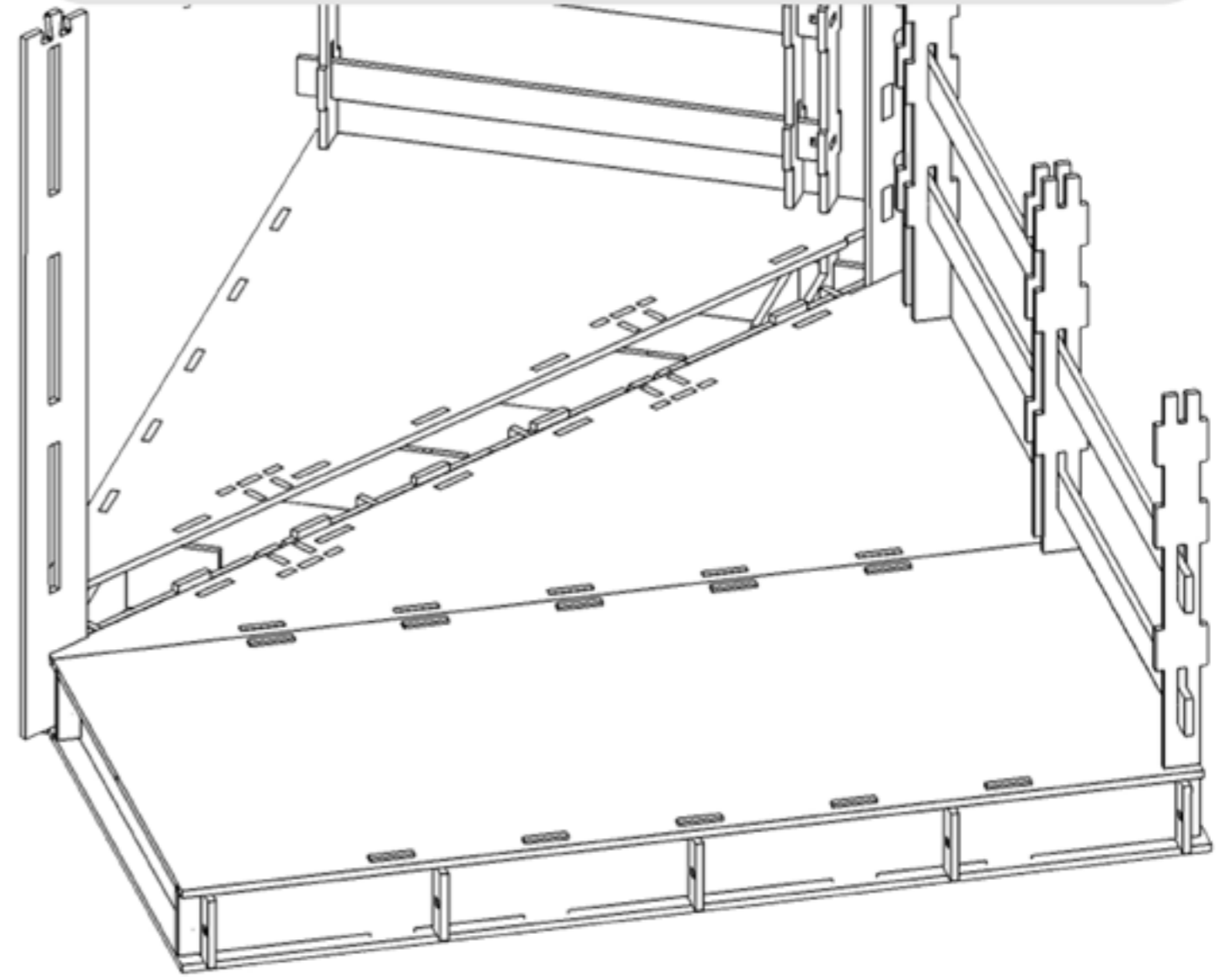
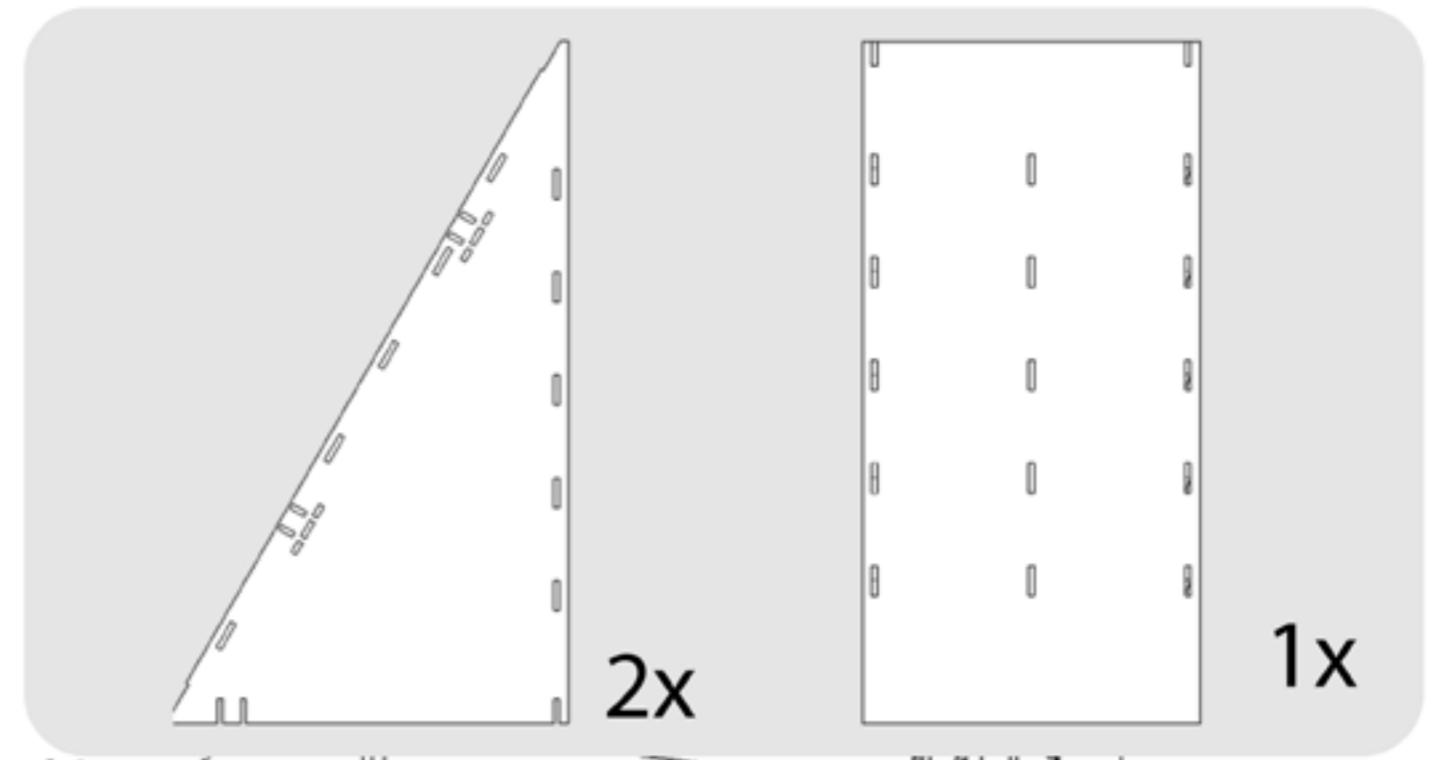
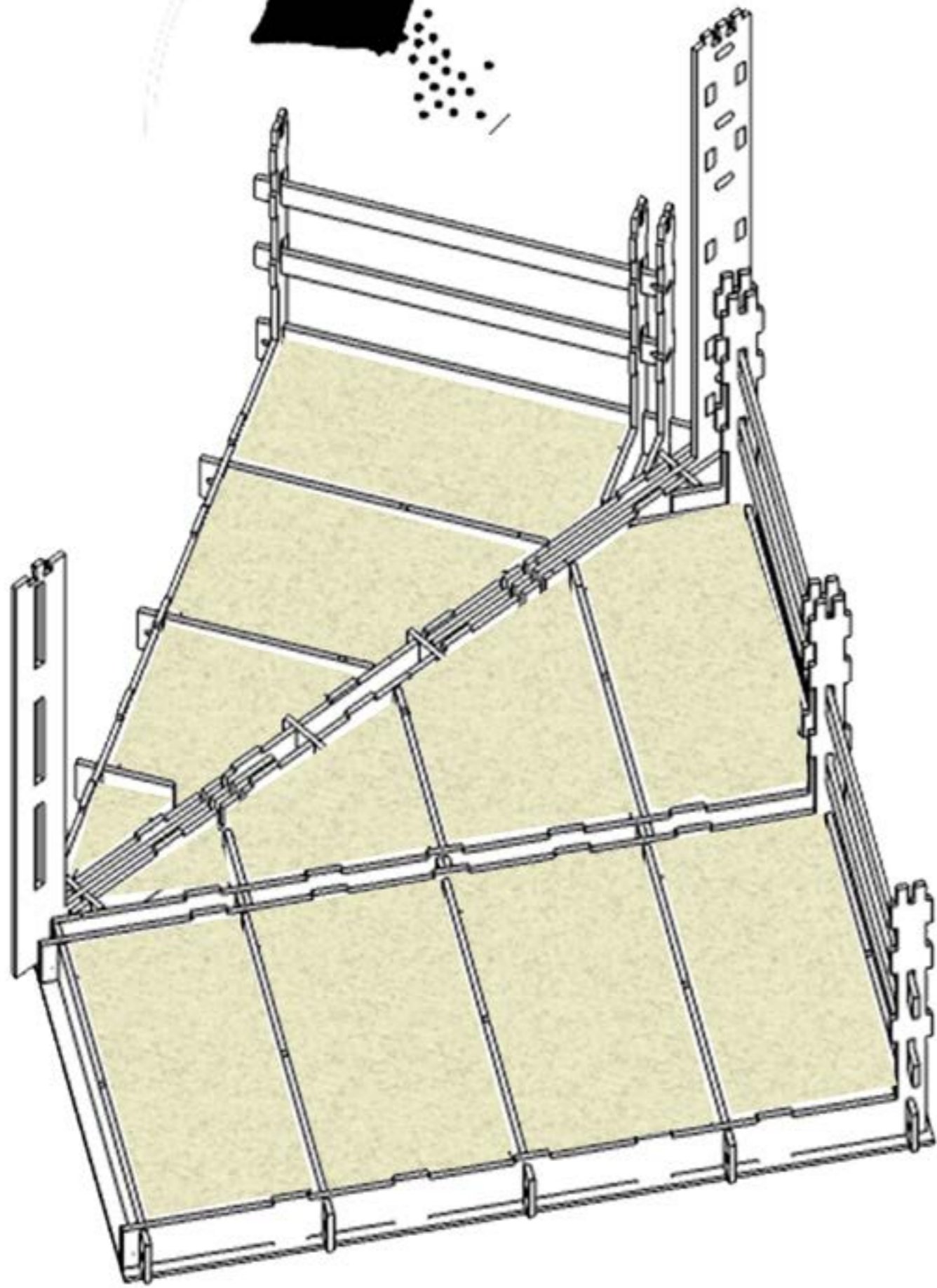



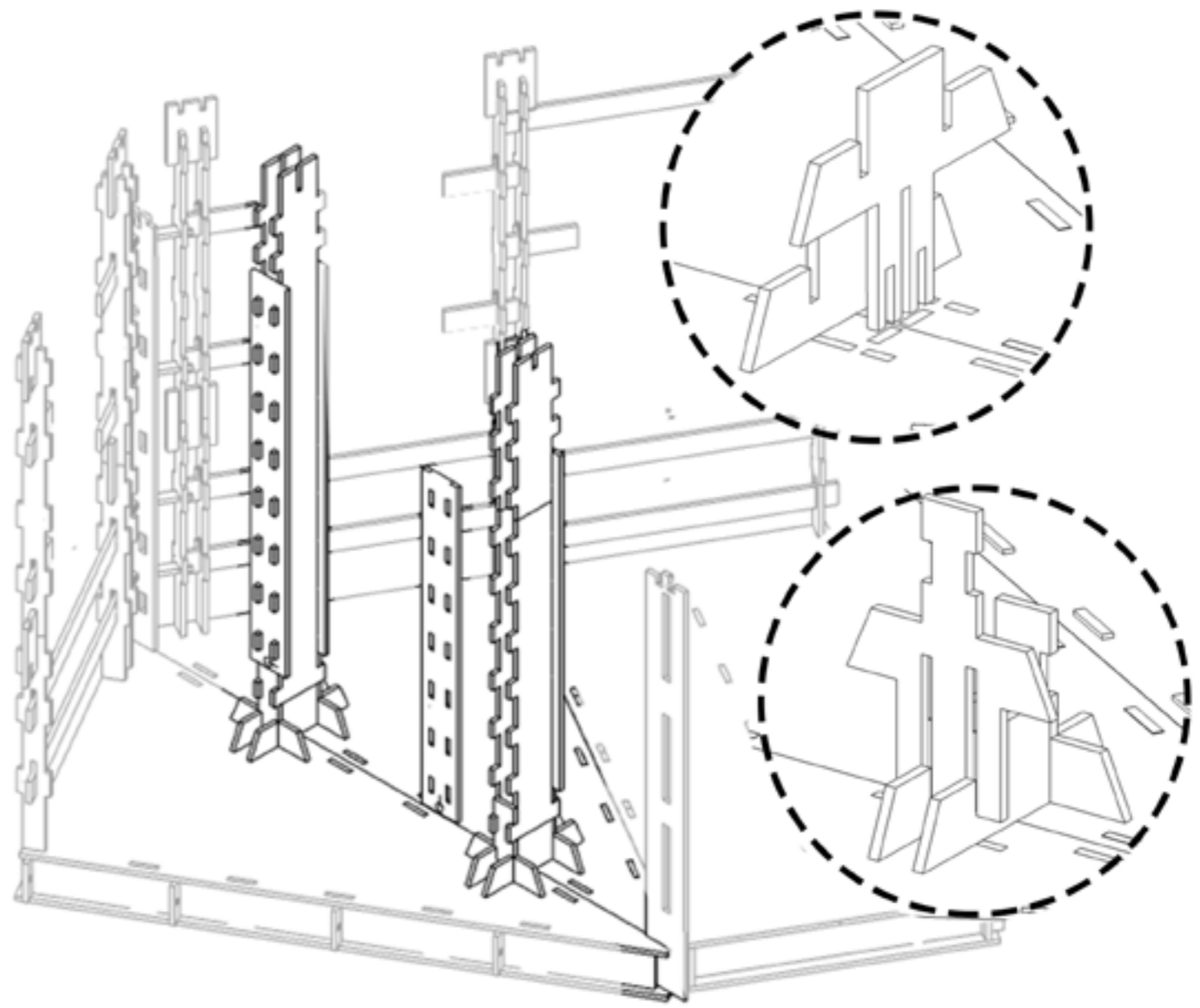
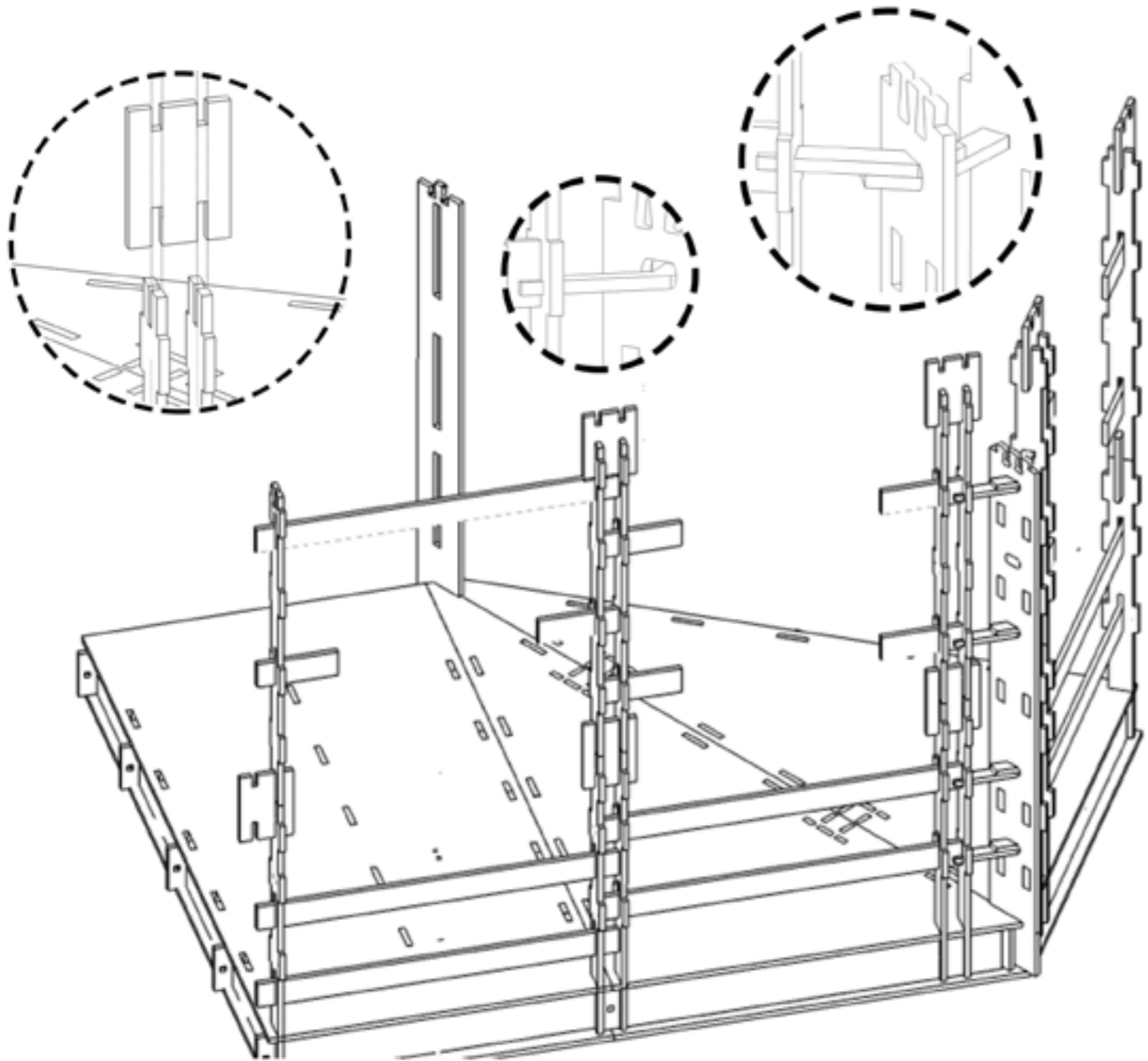
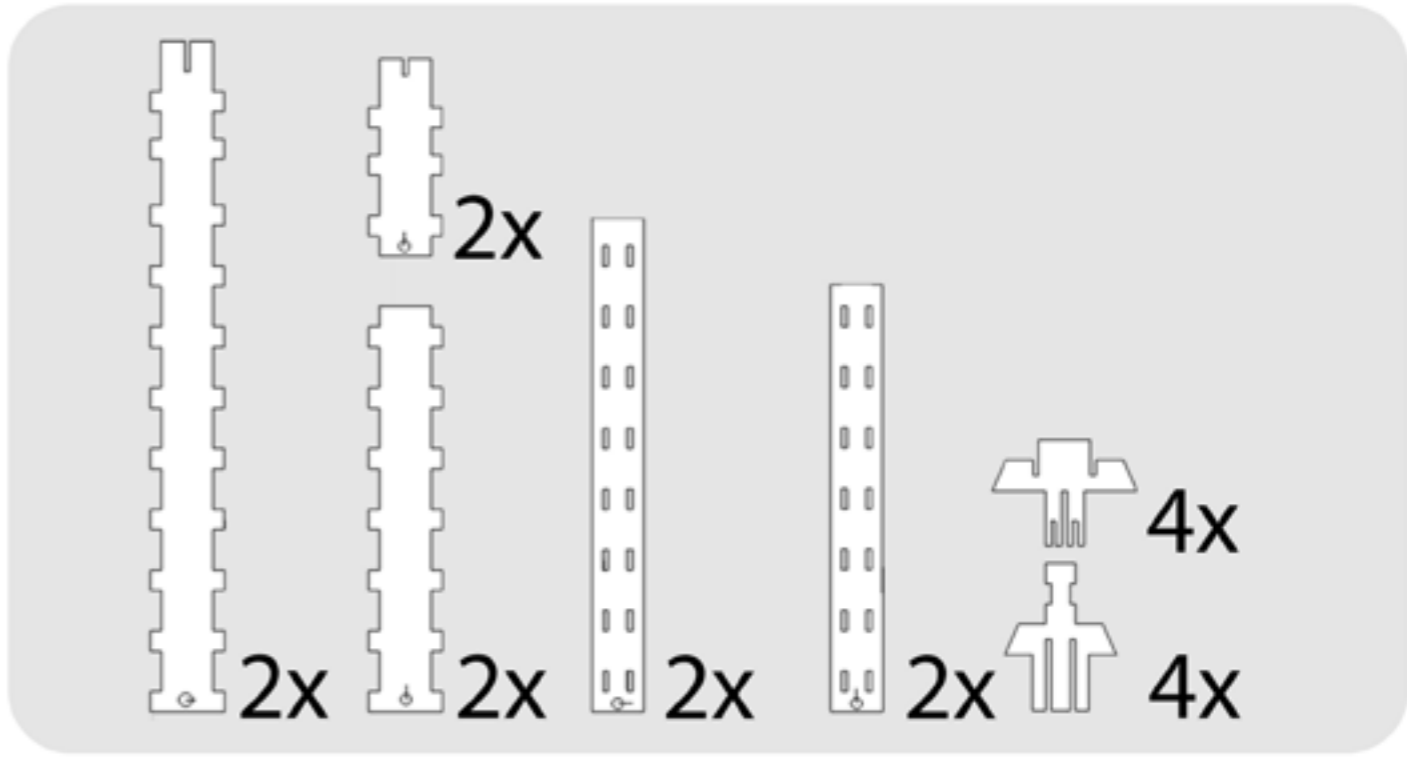
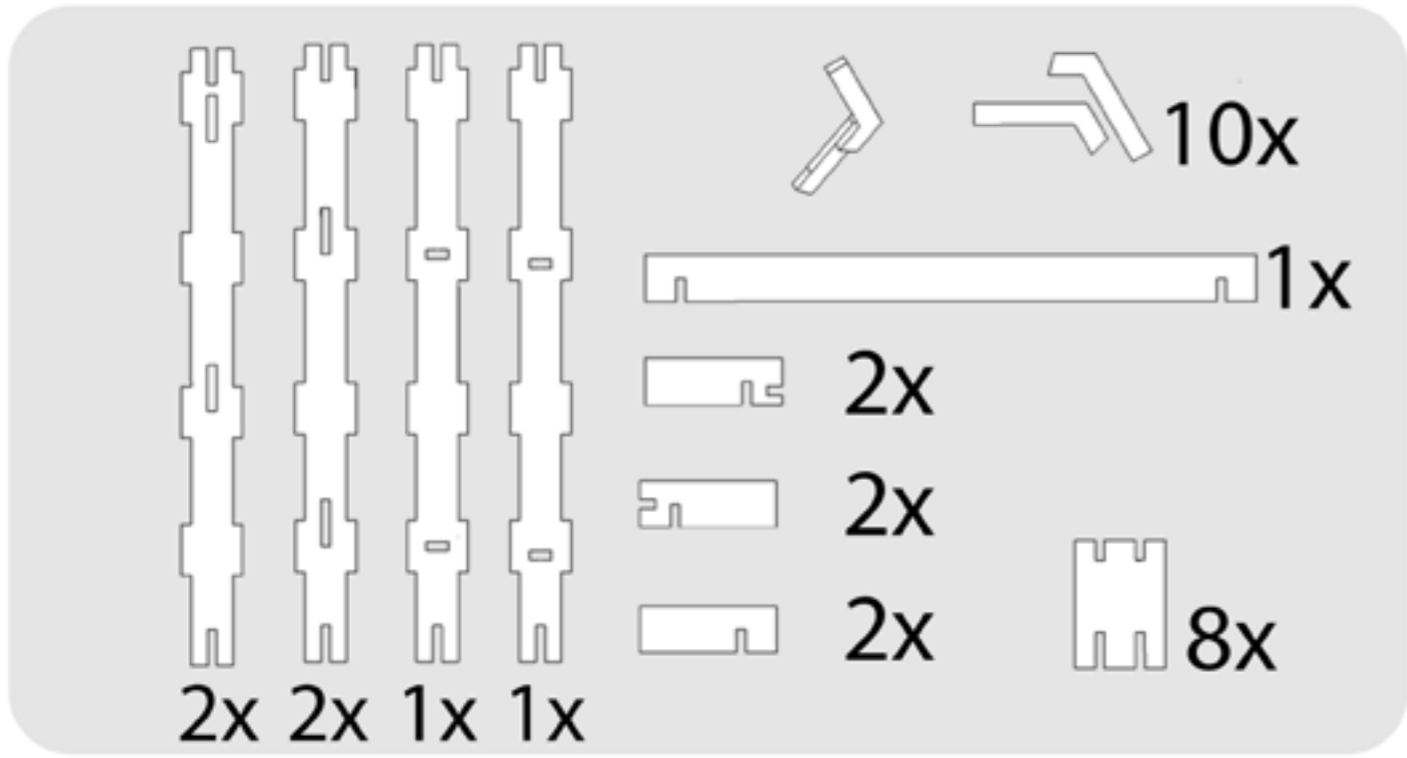

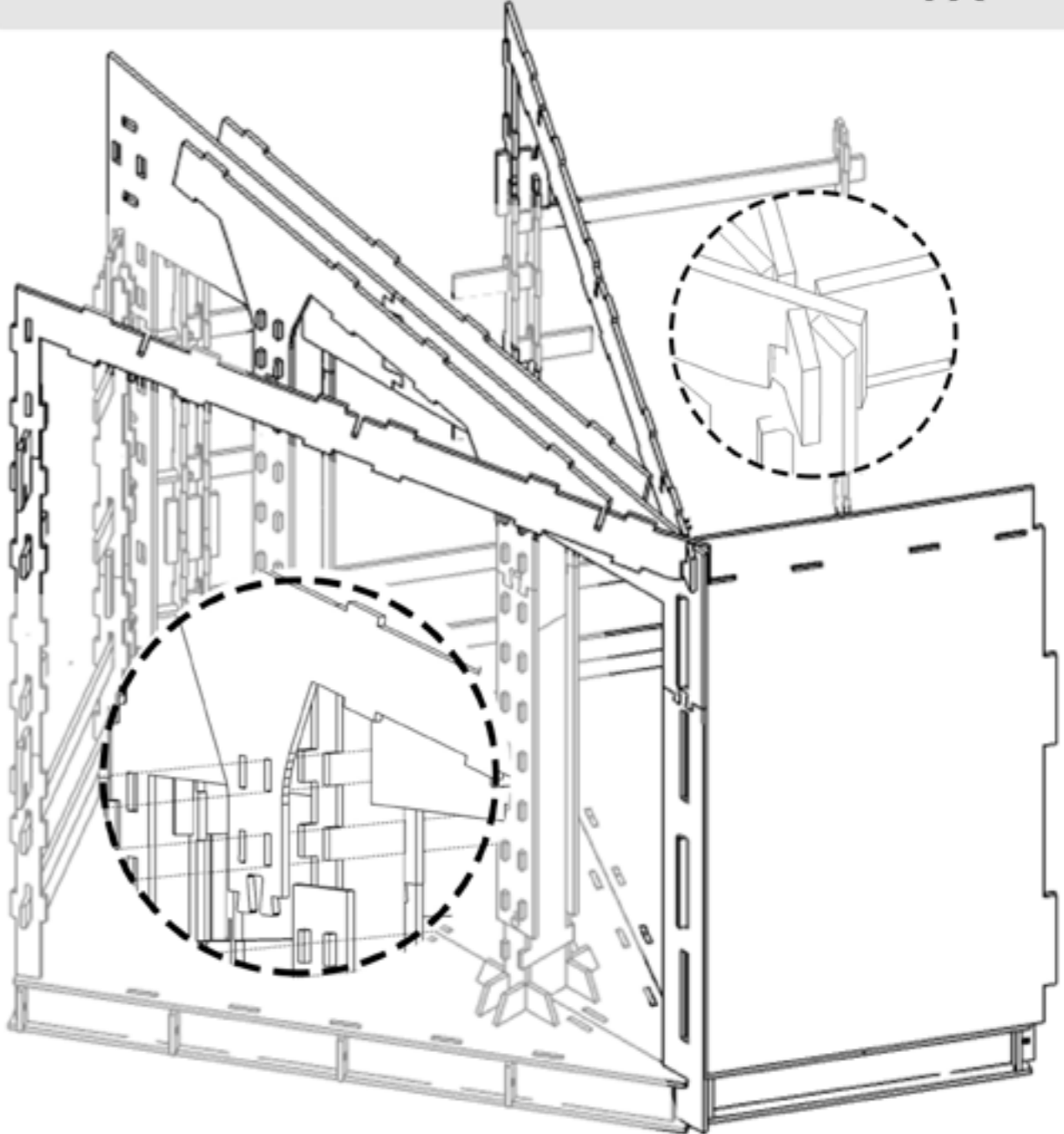
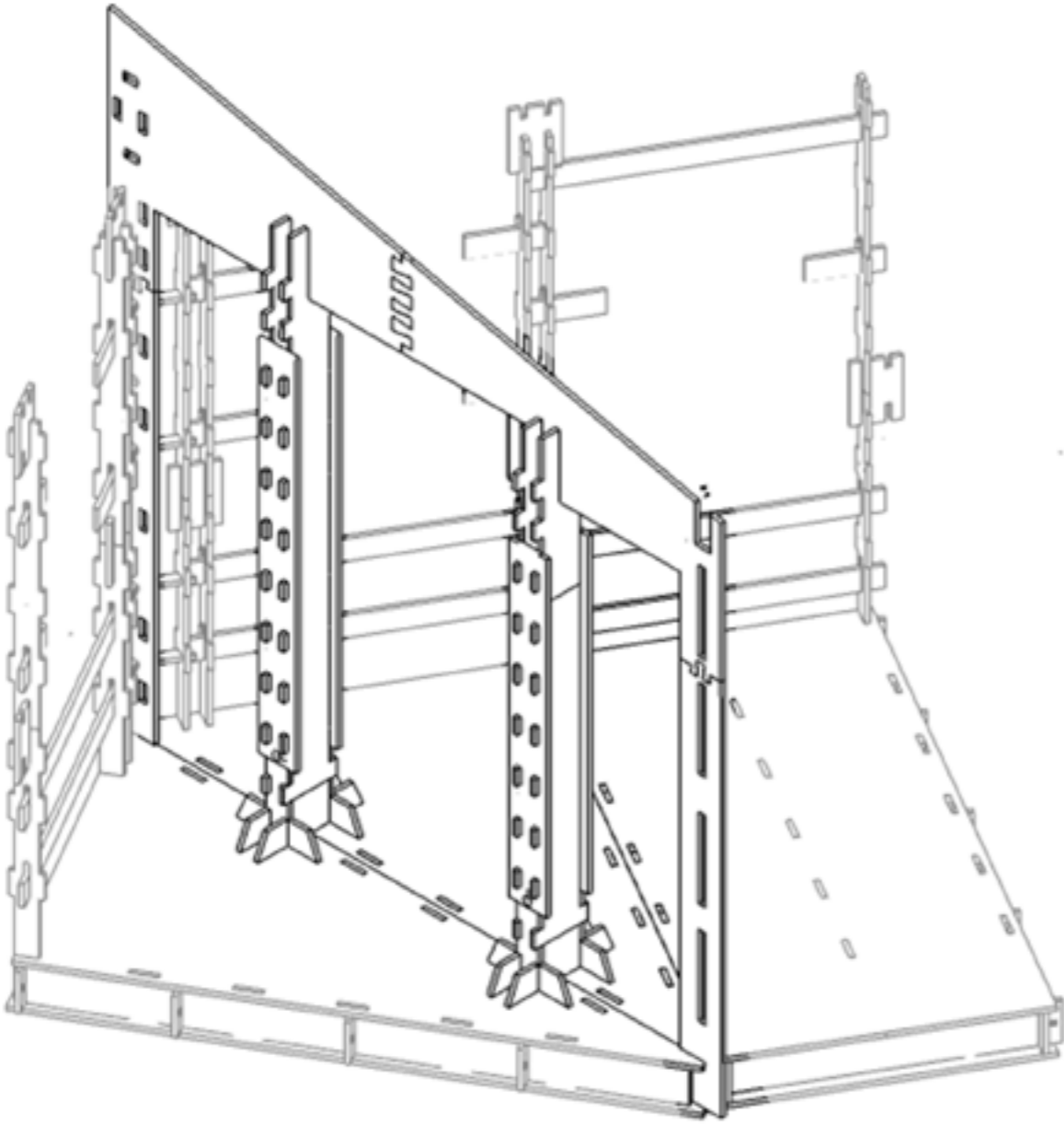
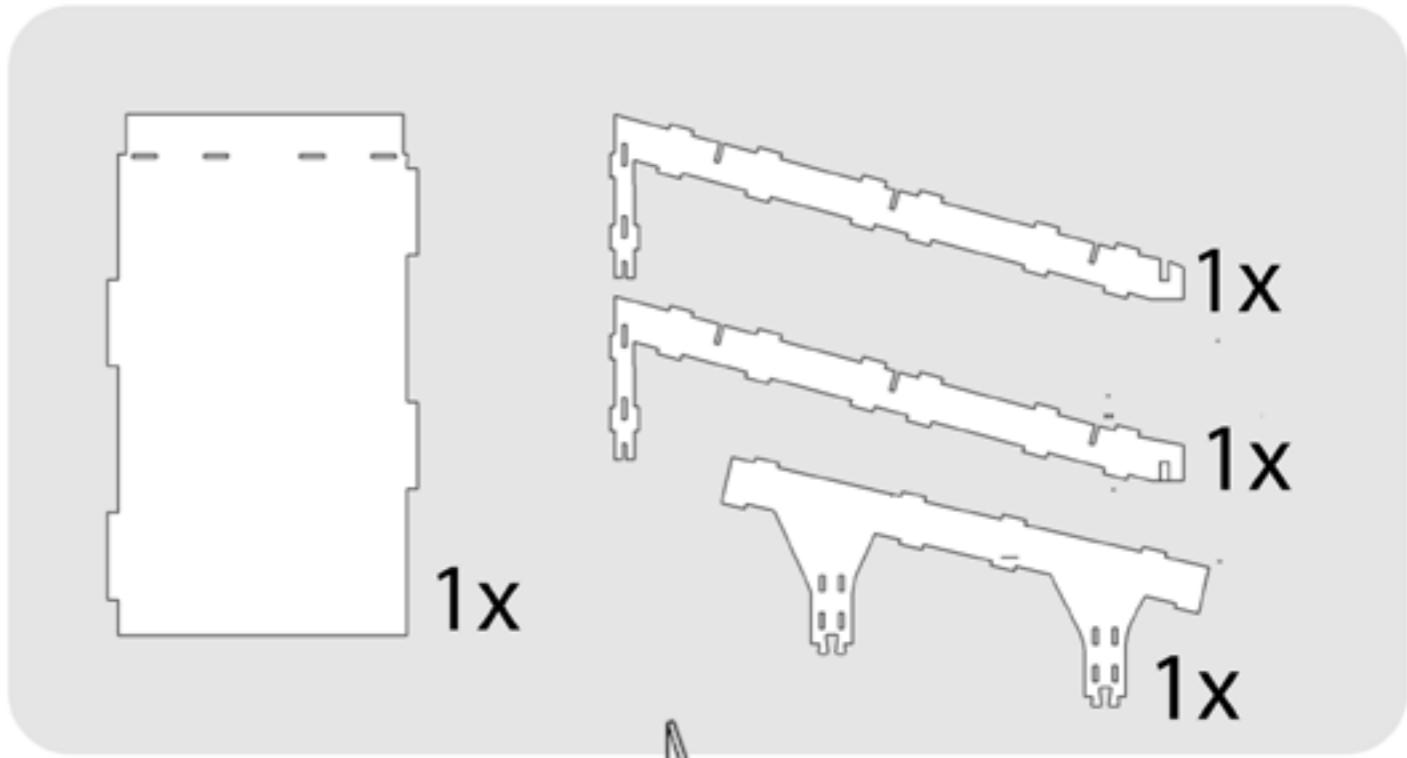
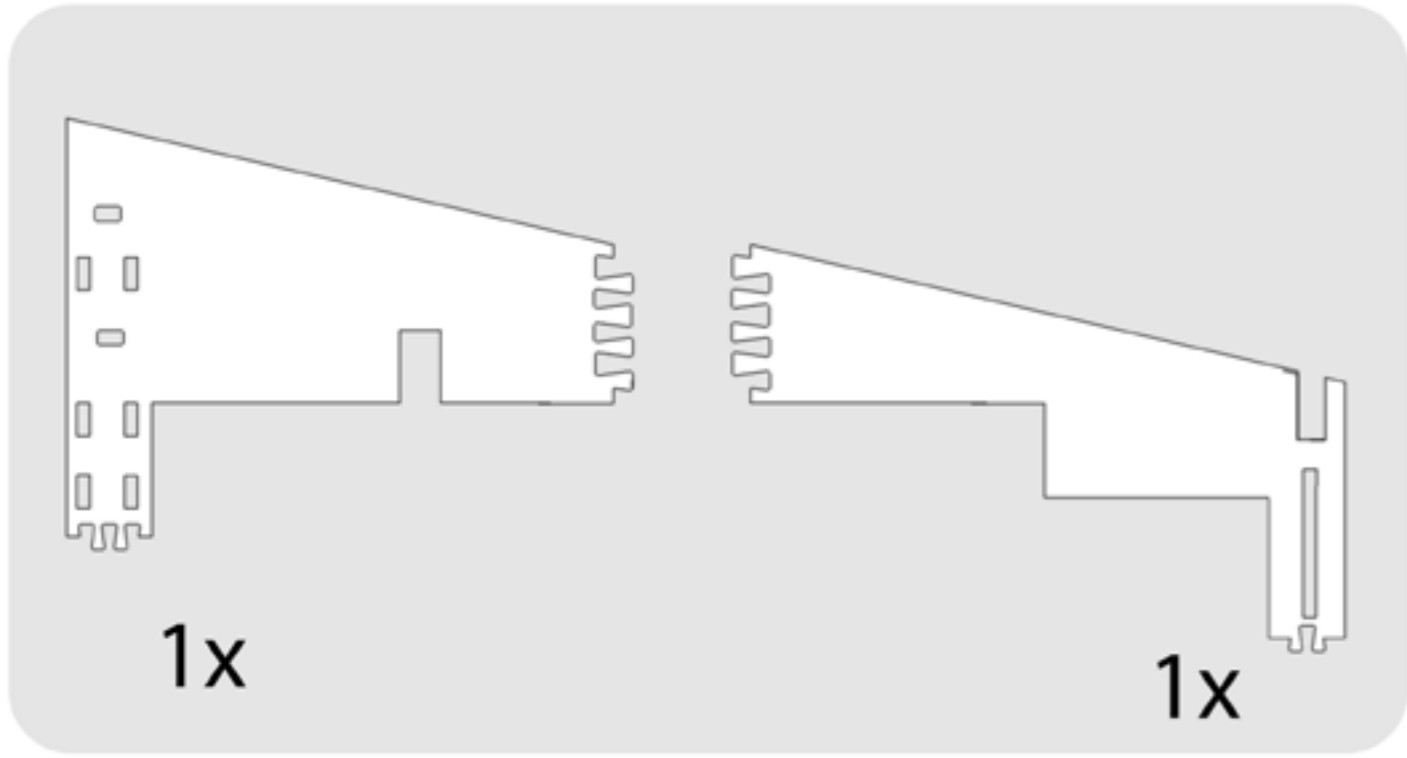



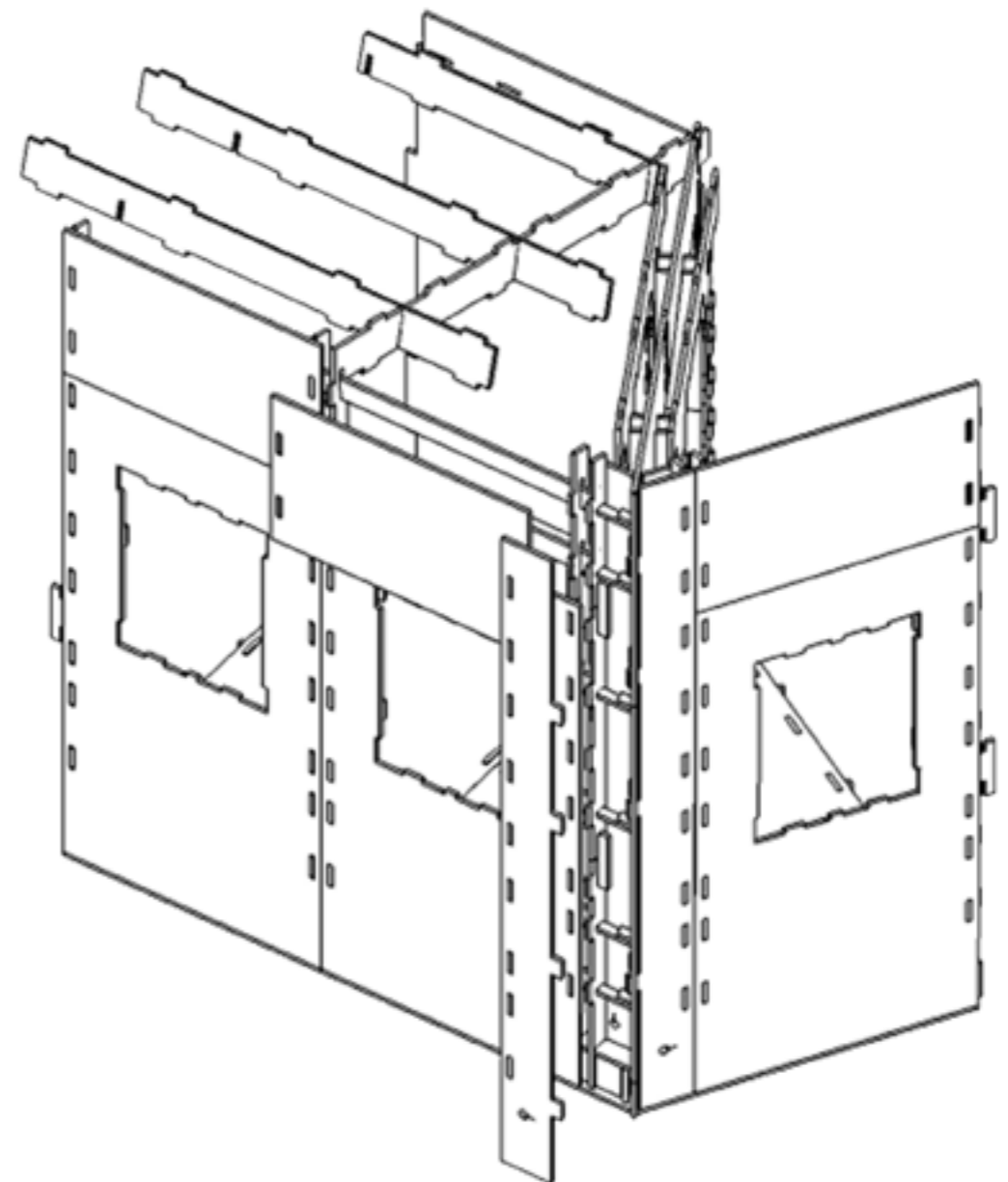
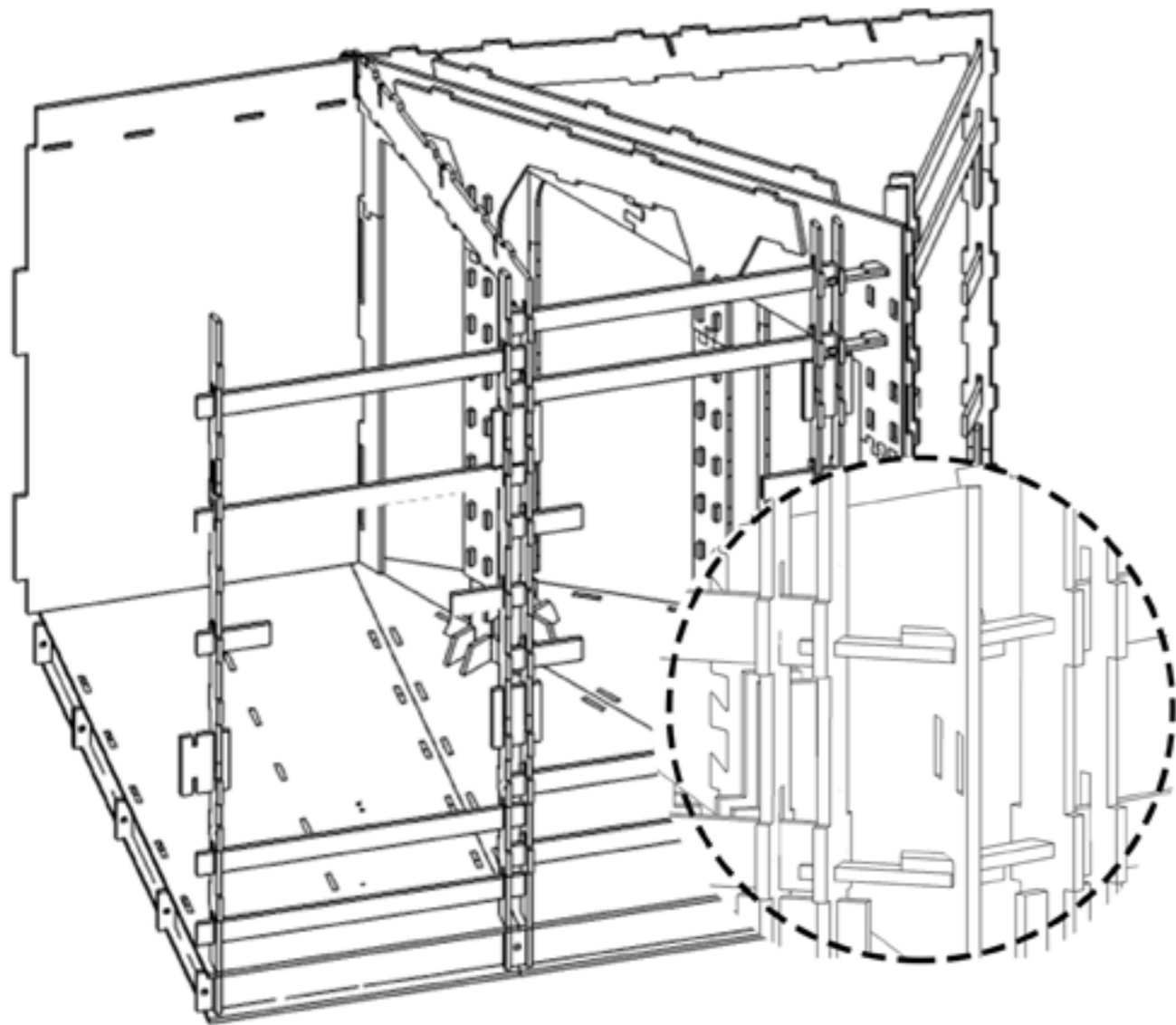
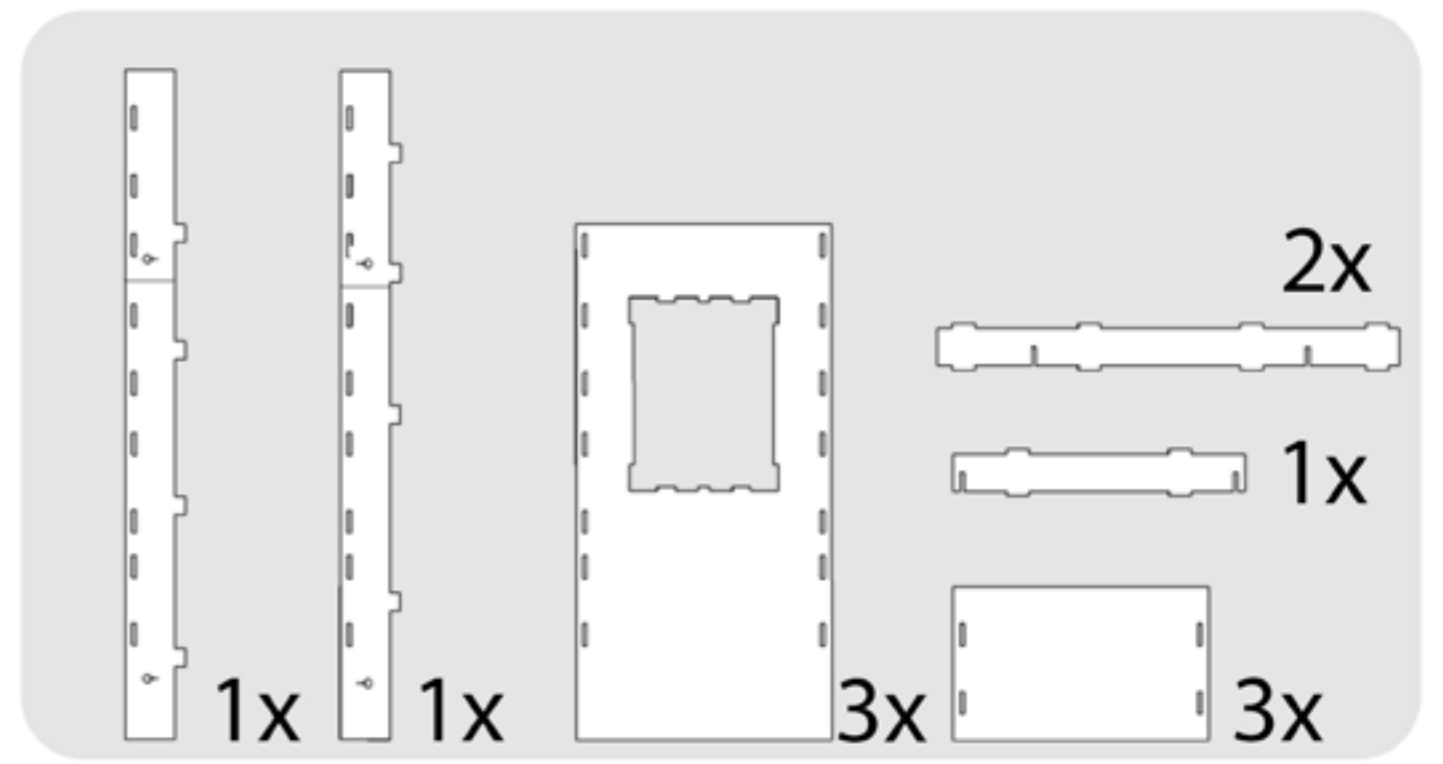
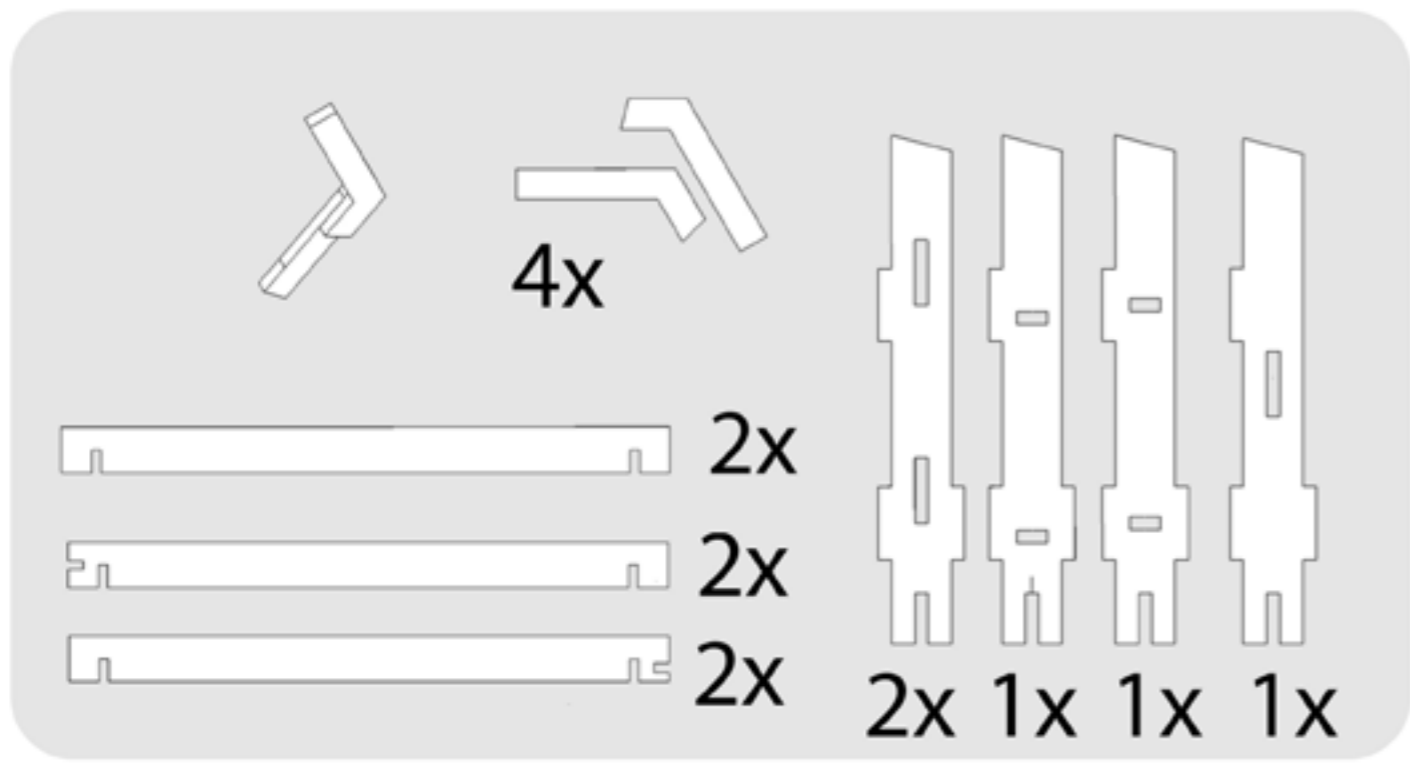

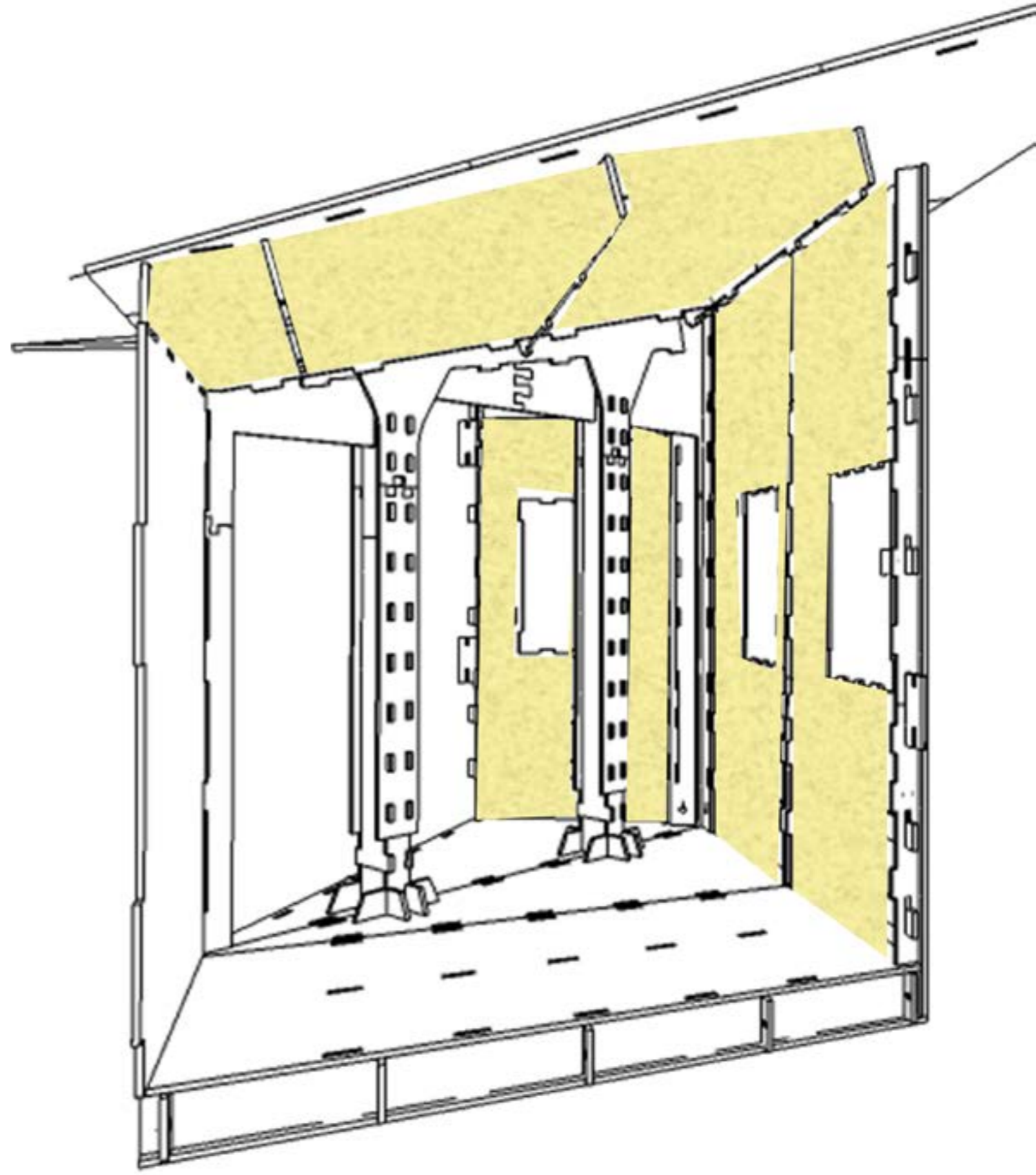
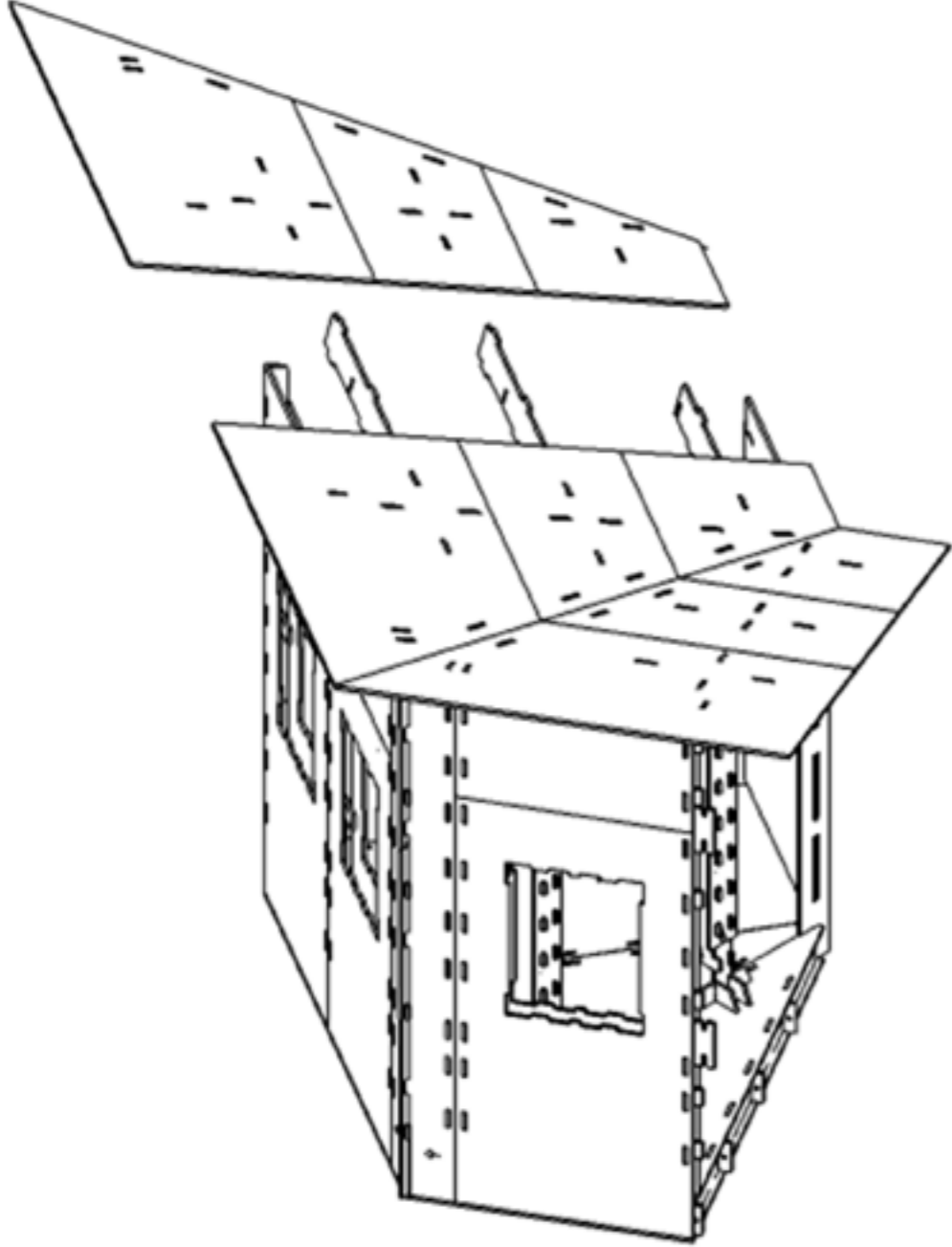
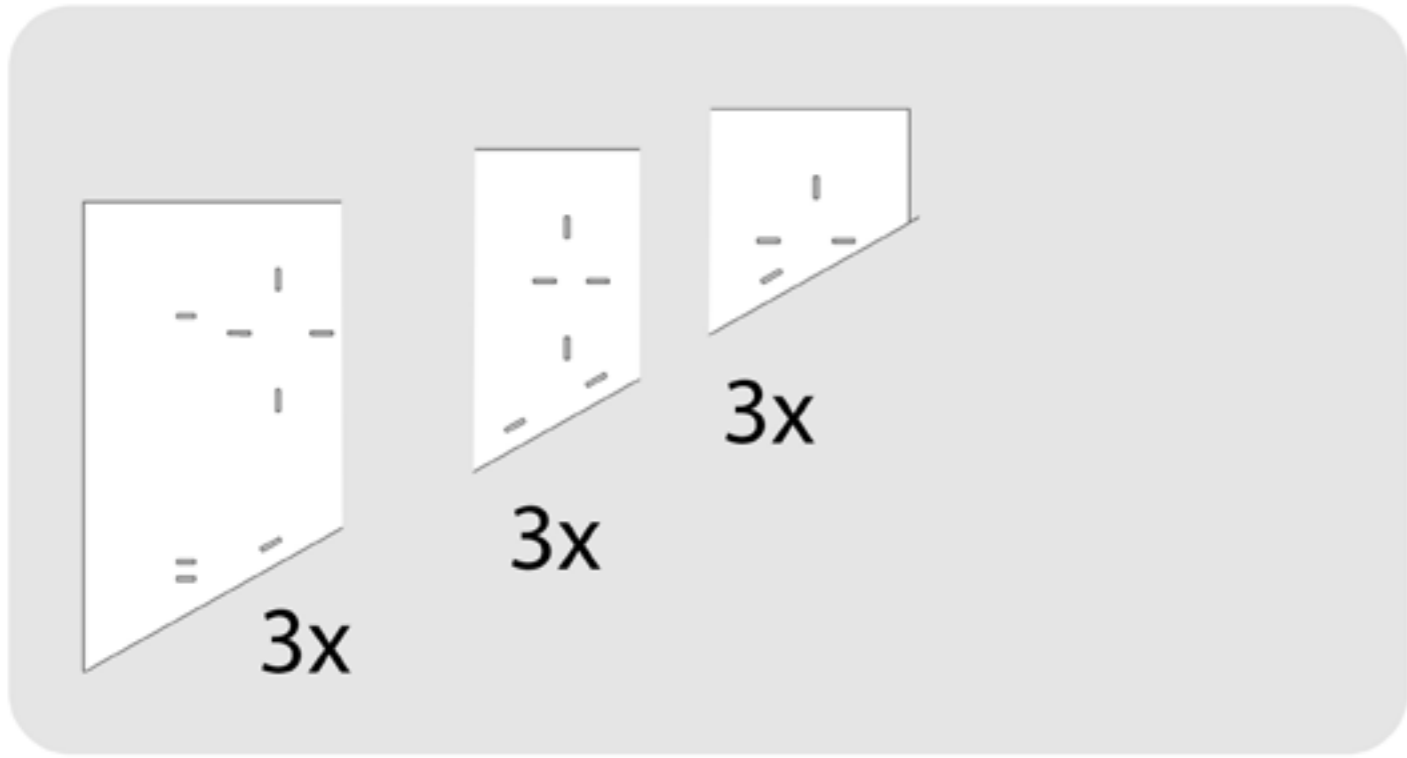

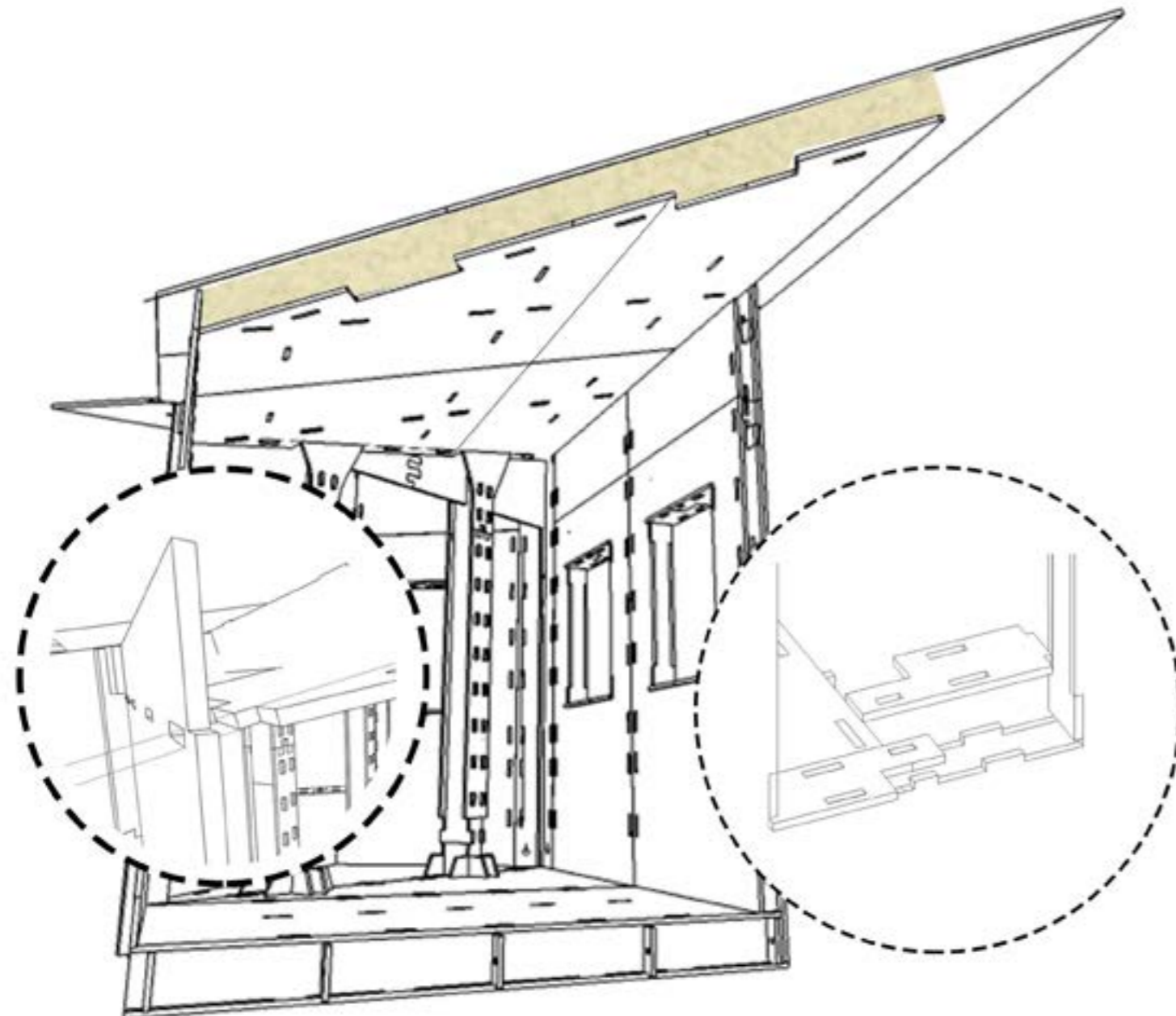

## Acknowledgements

The FabHouse was built in a study course, taken place at the Faculty of Communication and Environment at Rhine-Waal University of Applied Sciences, Campus Kamp-Lintfort.

For that, we want to say thank you to all the students involved in the process of thinking and making it: Anastasia Gilz, Andrian Beckmann, Clara Joana Gütte, Dominic Claßen, Jannatul Abedin, Julia Mertens, Konstantin Pfafenrod, Kuber Karki, Lennart Höffken, Melina Michala, Nico Zegelin and Omed Abed.

Thanks also to our sponsor [SIEGMETALL GmbH](http://www.siegmatal.com), who provided us with the material for roof of the house.

Thanks to the organizers of the course, namely Prof. Dr. Karsten Nebe, Ayse Esin Durmaz and Daniele Ingrassia, and the many helping hands of FabLab Kamp-Lintforts staff members Ahmed Belal-Mohamed-Ahmed-Abdellatif, Detlef Lau, Christian Spieß, Emir Rustamov, Jörg Kamps, Marvin Wiesner, Ole Langenbach.

A final special thanks goes to the dean of our faculty, Prof. Dr. Andreas Schürholz, who supported this project in finance.

Contact:

FabLab Kamp-Lintfort

Email: [fablab@hochschule-rhein-waal.de](mailto:fablab@hochschule-rhein-waal.de)

Web: <http://fablab.hochschule-rhein-waal.de>

Facebook: <http://facebook.com/fablabkamplintfort/>

Details about the project can be found at <http://fablab.hochschule-rhein-waal.de/fabhouse/>